



The Shade Primary School

Calculations Policy

Version:	3.0
Author:	Maths Subject Lead
Approved by:	Advisory Body
Date:	Summer 2024
Review date:	Summer 2027



The Shade Primary School Key Instant Recall Facts - KIRFs

	EYFS	Year One	Year Two	Year Three	Year Four	Year Five	Year Six
Autumn 1	I can recite numbers in order to 10.	I know number bonds to 10.	I know addition facts for all numbers to 20.	I can add three one-digit numbers.	I know the multiplication and division facts for the 4 and 8 times table.	I know the multiplication and division facts for all times tables up to 12x12 including the square numbers.	I can find the common factors of two numbers.
Autumn 2	I can recognise numerals 1 to 5.	I know number bonds for each number to 10.	I know subtraction facts for all numbers to 20.	I know all addition facts for multiples of 10 to 100.	I know the multiplication and division facts for the 12 times table.	I can find factors of numbers up to 100.	I can recall the prime numbers up to 19.
Spring 1	I can count 10 objects.	I can count in steps of 10 from 0.	I know the multiplication and division facts for the 10 times table.	I know the multiplication and division facts for the 3 times table.	I know the multiplication and division facts for the 7 & 11 times table.	I know decimal number bonds to 1.	I know halves of decimal numbers to 10.
Spring 2	I can say the number one more or one less (up to 10).	I know number bonds to 20.	I know the multiplication and division facts for the 5 times table.	I know the multiplication and division facts for the 6 times table.	I know doubles of numbers to 50.	I know halves of numbers to 200.	I can recall equivalences between fractions, decimals and percentages – halves, quarter, tenths and hundredths
Summer 1	I can order numbers from one to twenty.	I know doubles of numbers to 10.	I know doubles of numbers to 20.	I know the multiplication and division facts for the 9 times table.	I know the multiplication and division facts for all times tables up to 12x12.	I know decimal number bonds to 10.	I know doubles of two-digit decimal numbers.
Summer 2	I can add two single-digit numbers.	I know halves of even numbers to 10.	I know the multiplication and division facts for the 2 times table.	I know all subtraction facts for multiples of 10 to 100.	I can write equivalences between fractions and decimals – halves, quarters, tenths and hundredths	I know doubles of numbers to 100.	I know some cube numbers and can calculate others.

Reception

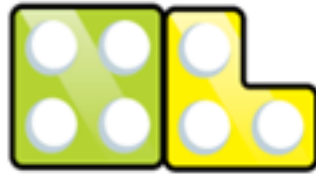
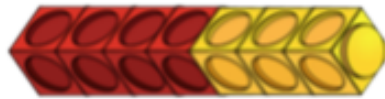
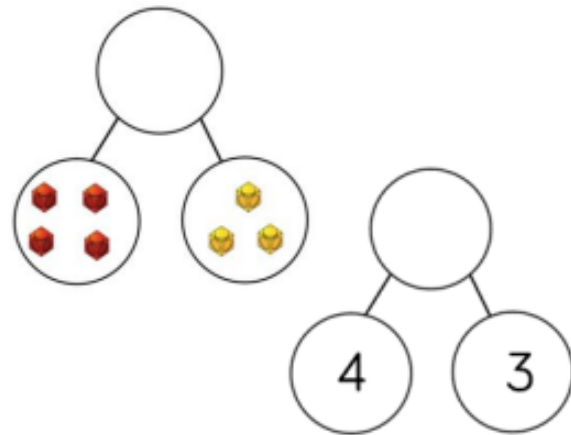

First

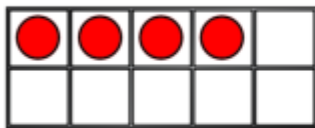

Then

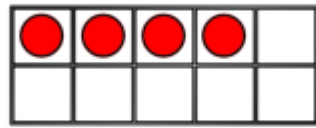

$$4 + 3 = 7$$

Now

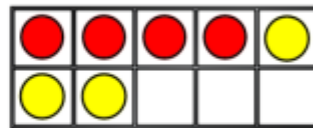

Understand the 'one more than/one less than' relationship between consecutive numbers.

Explore the composition of numbers to 10.

Automatically recall number bonds for numbers 0-5 and some to 10.

Year 1 - 6

Calculation Policy

Addition and Subtraction

[#MathsEveryoneCan](#)



Calculation Policy

Welcome to the White Rose Maths Calculation Policy.

This document is broken down into addition and subtraction, and multiplication and division.

At the start of each policy, there is an overview of the different models and images that can support the teaching of different concepts. These provide explanations of the benefits of using the models and show the links between different operations.

Ten Frames (within 20)

$8 + 7 = 15$

$14 - 6 = 8$

$7 + 6 + 3 = 16$

Benefits

When adding two single digits, children can make each number on separate ten frames before moving part of one number to make 10 on one of the ten frames. This supports children to see how they have partitioned one of the numbers to make 10, and makes links to effective mental methods of addition.

When subtracting a one-digit number from a two-digit number, firstly make the larger number on 2 ten frames. Remove the smaller number, thinking carefully about how you have partitioned the number to make 10, this supports mental methods of subtraction.

When adding three single-digit numbers, children can make each number on 3 separate 10 frames before considering which order to add the numbers in. They may be able to find a number bond to 10 which makes the calculation easier. Once again, the ten frames support the link to effective mental methods of addition as well as the importance of commutativity.

Each operation is then broken down into skills and each skill has a dedicated page showing the different models and images that could be used to effectively teach that concept.

Skill: Add 1 and 2-digit numbers to 20

Year: 1/2

When adding one-digit numbers that cross 10, it is important to highlight the importance of ten ones equaling one ten.

Different manipulatives can be used to represent this exchange. Use concrete resources alongside number lines to support children in understanding how to partition their jumps.

There is an overview of skills linked to year groups to support consistency through out school. A glossary of terms is provided at the end of the calculation policy to support understanding of the key language used to teach the four operations.

Part-Whole Model

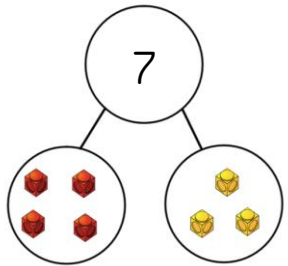

$$7 = 4 + 3$$

$$7 = 3 + 4$$

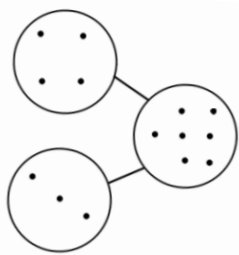

$$7 - 3 = 4$$

$$7 - 4 = 3$$

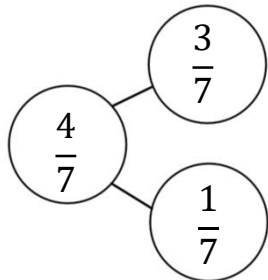
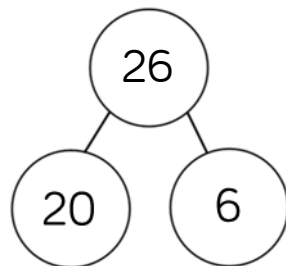
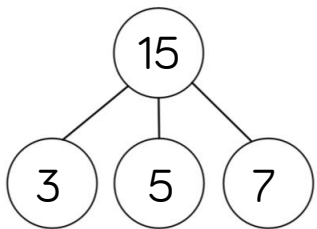
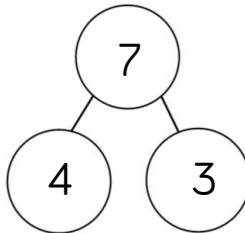

Benefits

This part-whole model supports children in their understanding of aggregation and partitioning. Due to its shape, it can be referred to as a cherry part-whole model.

When the parts are complete and the whole is empty, children use aggregation to add the parts together to find the total.

When the whole is complete and at least one of the parts is empty, children use partitioning (a form of subtraction) to find the missing part.

Part-whole models can be used to partition a number into two or more parts, or to help children to partition a number into tens and ones or other place value columns.

In KS2, children can apply their understanding of the part-whole model to add and subtract fractions, decimals and percentages.

Bar Model (single)

Concrete



Discrete

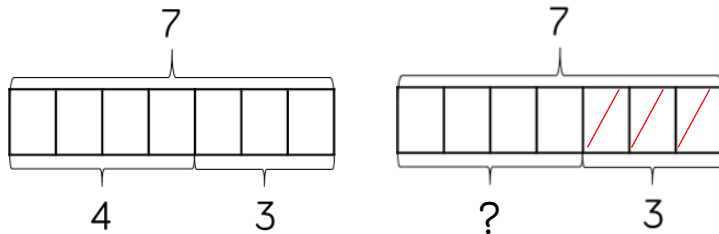

Combination

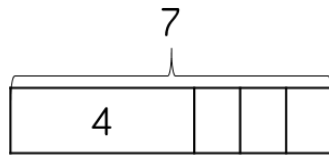

Continuous

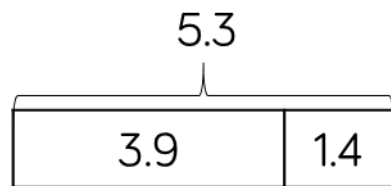
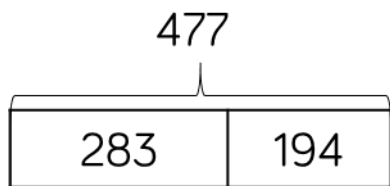
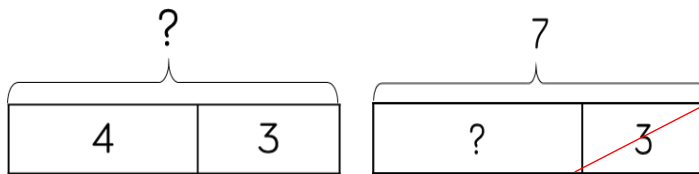

Benefits

The single bar model is another type of a part-whole model that can support children in representing calculations to help them unpick the structure.

Cubes and counters can be used in a line as a concrete representation of the bar model.

Discrete bar models are a good starting point with smaller numbers. Each box represents one whole.

The combination bar model can support children to calculate by counting on from the larger number. It is a good stepping stone towards the continuous bar model.

Continuous bar models are useful for a range of values. Each rectangle represents a number. The question mark indicates the value to be found.

In KS2, children can use bar models to represent larger numbers, decimals and fractions.

Bar Model (multiple)

Discrete

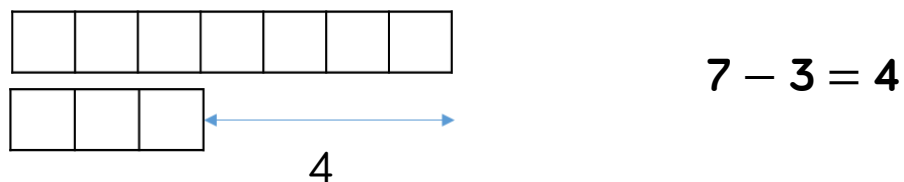
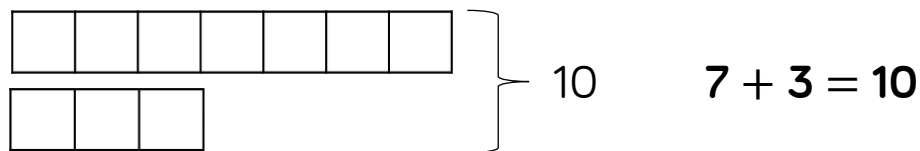

Continuous

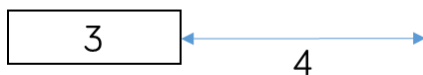
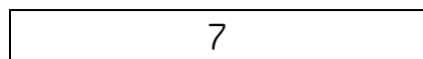

$$7 - 3 = 4$$

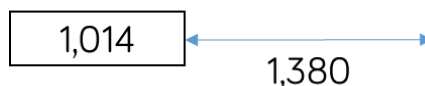
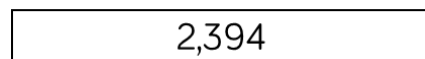

$$2,394 - 1,014 = 1,380$$

Benefits

The multiple bar model is a good way to compare quantities whilst still unpicking the structure.

Two or more bars can be drawn, with a bracket labelling the whole positioned on the right hand side of the bars. Smaller numbers can be represented with a discrete bar model whilst continuous bar models are more effective for larger numbers.

Multiple bar models can also be used to represent the difference in subtraction. An arrow can be used to model the difference.

When working with smaller numbers, children can use cubes and a discrete model to find the difference. This supports children to see how counting on can help when finding the difference.

Number Shapes



$$7 = 4 + 3$$



$$7 = 3 + 4$$

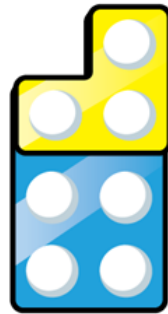

$$7 - 3 = 4$$

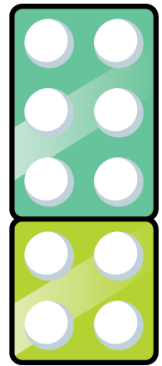

$$6 + 4$$

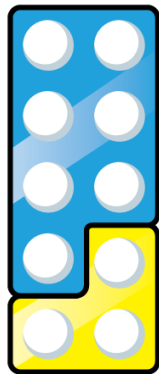

$$7 + 3$$

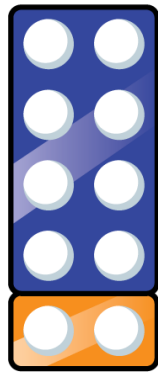

$$8 + 2$$

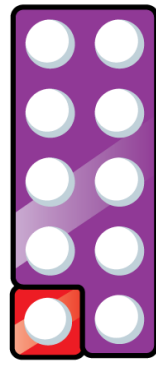

$$9 + 1$$

Benefits

Number shapes can be useful to support children to subitise numbers as well as explore aggregation, partitioning and number bonds.

When adding numbers, children can see how the parts come together making a whole. As children use number shapes more often, they can start to subitise the total due to their familiarity with the shape of each number.

When subtracting numbers, children can start with the whole and then place one of the parts on top of the whole to see what part is missing. Again, children will start to be able to subitise the part that is missing due to their familiarity with the shapes.

Children can also work systematically to find number bonds. As they increase one number by 1, they can see that the other number decreases by 1 to find all the possible number bonds for a number.

Cubes

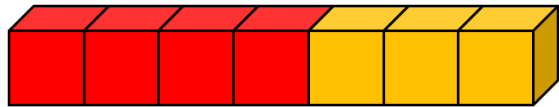

$$7 = 4 + 3$$

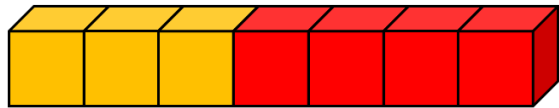

$$7 = 3 + 4$$

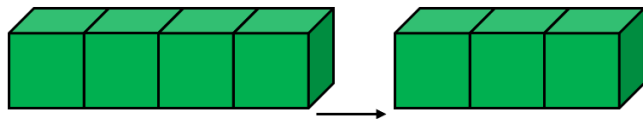

$$7 - 3 = 4$$

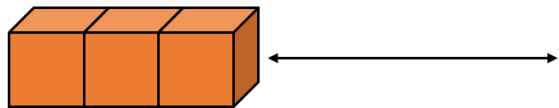
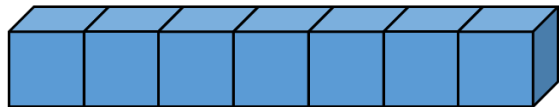

$$7 - 3 = 4$$

Benefits

Cubes can be useful to support children with the addition and subtraction of one-digit numbers.

When adding numbers, children can see how the parts come together to make a whole. Children could use two different colours of cubes to represent the numbers before putting them together to create the whole.

When subtracting numbers, children can start with the whole and then remove the number of cubes that they are subtracting in order to find the answer. This model of subtraction is reduction, or take away.

Cubes can also be useful to look at subtraction as difference. Here, both numbers are made and then lined up to find the difference between the numbers.

Cubes are useful when working with smaller numbers but are less efficient with larger numbers as they are difficult to subitise and children may miscount them.

Ten Frames (within 10)

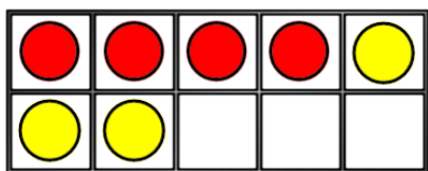

$$4 + 3 = 7$$

$$3 + 4 = 7$$

$$7 - 3 = 4$$

$$7 - 4 = 3$$

4 is a part.

3 is a part.

7 is the whole.

First

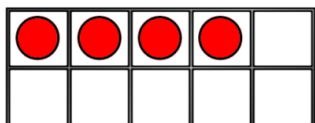

Then

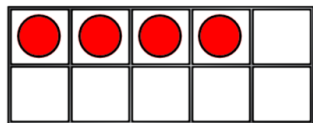

$$4 + 3 = 7$$

Now

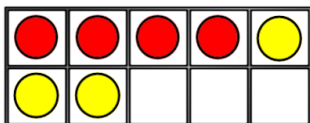

First

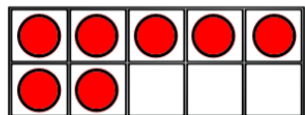

Then

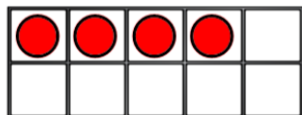

$$7 - 3 = 4$$

Now

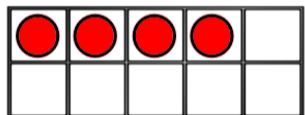

Benefits

When adding and subtracting within 10, the ten frame can support children to understand the different structures of addition and subtraction.

Using the language of parts and wholes represented by objects on the ten frame introduces children to aggregation and partitioning.

Aggregation is a form of addition where parts are combined together to make a whole. Partitioning is a form of subtraction where the whole is split into parts. Using these structures, the ten frame can enable children to find all the number bonds for a number.

Children can also use ten frames to look at augmentation (increasing a number) and take-away (decreasing a number). This can be introduced through a first, then, now structure which shows the change in the number in the 'then' stage. This can be put into a story structure to help children understand the change e.g. First, there were 7 cars. Then, 3 cars left. Now, there are 4 cars.

Ten Frames (within 20)

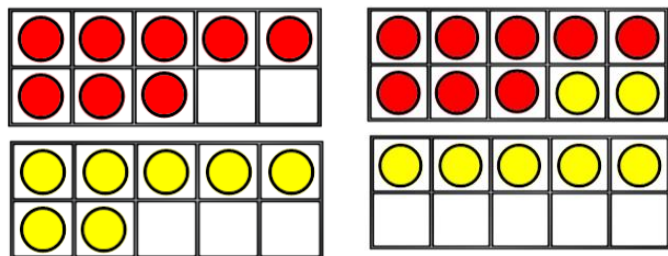

$$8 + 7 = 15$$

Diagram showing 8 partitioned into 2 and 5. A blue oval encircles the 8 and the 2, with lines connecting the 2 to the 8 and the 5 to the 7.

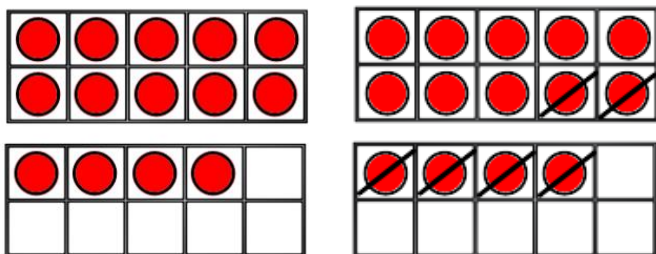

$$14 - 6 = 8$$

Diagram showing 14 partitioned into 4 and 2. A blue oval encircles the 14 and the 4, with lines connecting the 4 to the 14 and the 2 to the 6.

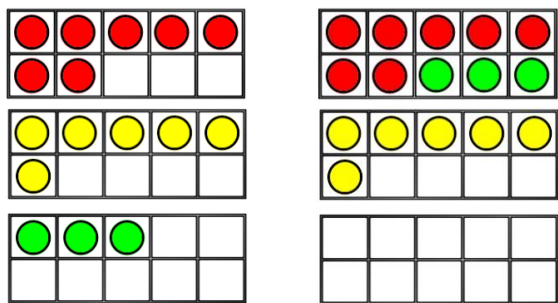

$$7 + 6 + 3 = 16$$

Diagram showing 10 partitioned into 7 and 3. Lines connect the 10 to the 7 and the 3.

Benefits

When adding two single digits, children can make each number on separate ten frames before moving part of one number to make 10 on one of the ten frames. This supports children to see how they have partitioned one of the numbers to make 10, and makes links to effective mental methods of addition.

When subtracting a one-digit number from a two-digit number, firstly make the larger number on 2 ten frames. Remove the smaller number, thinking carefully about how you have partitioned the number to make 10, this supports mental methods of subtraction.

When adding three single-digit numbers, children can make each number on 3 separate 10 frames before considering which order to add the numbers in. They may be able to find a number bond to 10 which makes the calculation easier. Once again, the ten frames support the link to effective mental methods of addition as well as the importance of commutativity.

Bead Strings

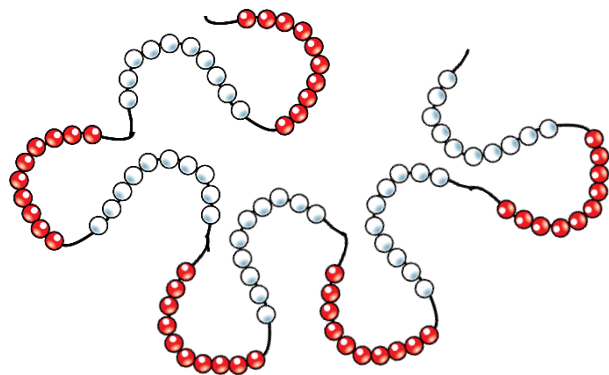
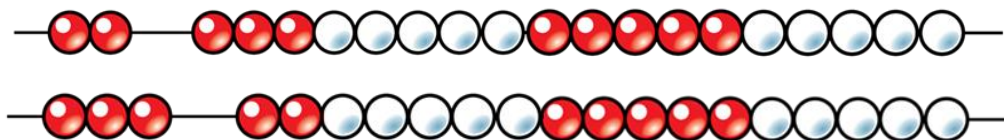
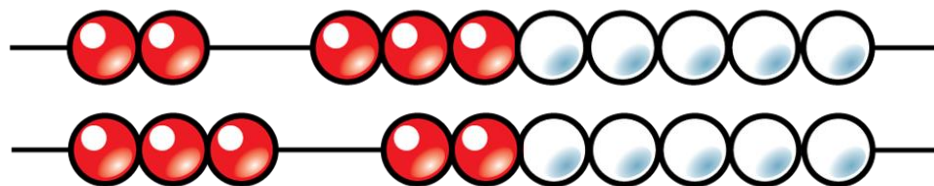

Benefits

Different sizes of bead strings can support children at different stages of addition and subtraction.

Bead strings to 10 are very effective at helping children to investigate number bonds up to 10.

They can help children to systematically find all the number bonds to 10 by moving one bead at a time to see the different numbers they have partitioned the 10 beads into e.g. $2 + 8 = 10$, move one bead, $3 + 7 = 10$.

Bead strings to 20 work in a similar way but they also group the beads in fives. Children can apply their knowledge of number bonds to 10 and see the links to number bonds to 20.

Bead strings to 100 are grouped in tens and can support children in number bonds to 100 as well as helping when adding by making ten. Bead strings can show a link to adding to the next 10 on number lines which supports a mental method of addition.

Number Tracks

$$5 + 3 = 8$$

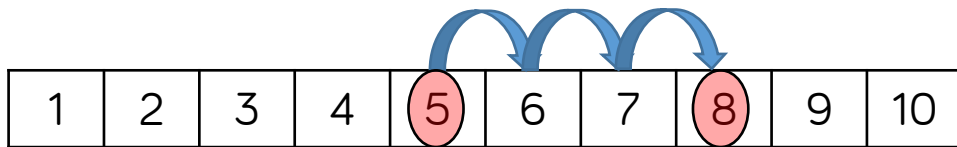

$$10 - 4 = 6$$

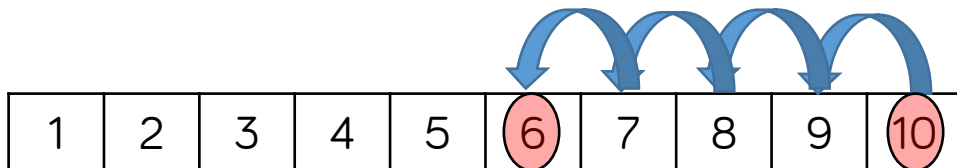

$$8 + 7 = 15$$

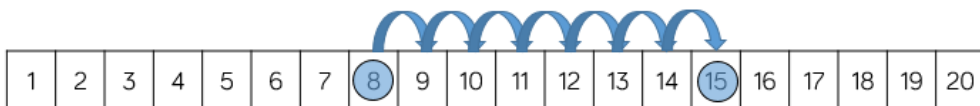

Benefits

Number tracks are useful to support children in their understanding of augmentation and reduction.

When adding, children count on to find the total of the numbers. On a number track, children can place a counter on the starting number and then count on to find the total.

When subtracting, children count back to find their answer. They start at the minuend and then take away the subtrahend to find the difference between the numbers.

Number tracks can work well alongside ten frames and bead strings which can also model counting on or counting back.

Playing board games can help children to become familiar with the idea of counting on using a number track before they move on to number lines.

Number Lines (labelled)

$$5 + 3 = 8$$

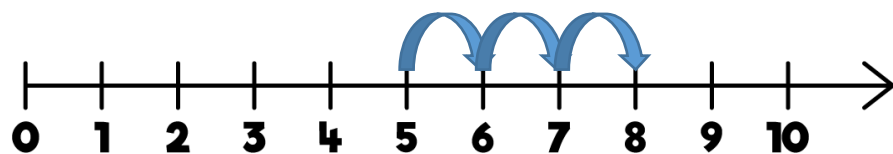

$$8 + 7 = 15$$

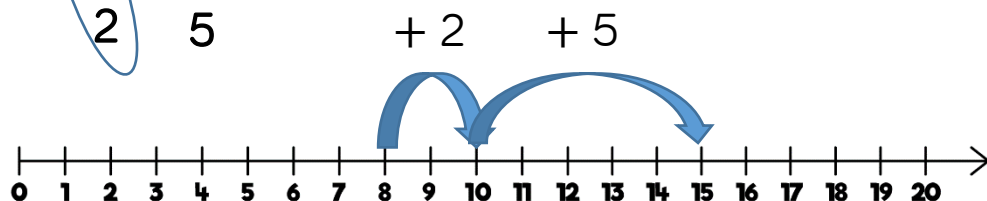
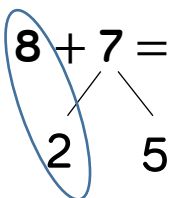

$$14 - 6 = 8$$

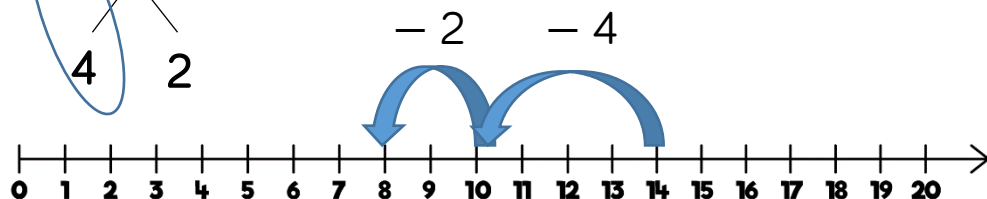
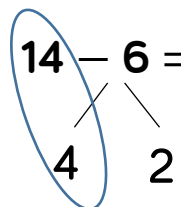

Benefits

Labelled number lines support children in their understanding of addition and subtraction as augmentation and reduction.

Children can start by counting on or back in ones, up or down the number line. This skill links directly to the use of the number track.

Progressing further, children can add numbers by jumping to the nearest 10 and then jumping to the total. This links to the making 10 method which can also be supported by ten frames. The smaller number is partitioned to support children to make a number bond to 10 and to then add on the remaining part.

Children can subtract numbers by firstly jumping to the nearest 10. Again, this can be supported by ten frames so children can see how they partition the smaller number into the two separate jumps.

Number Lines (blank)

$$35 + 37 = 72$$

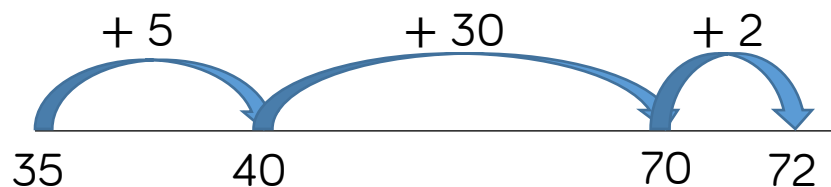

$$35 + 37 = 72$$

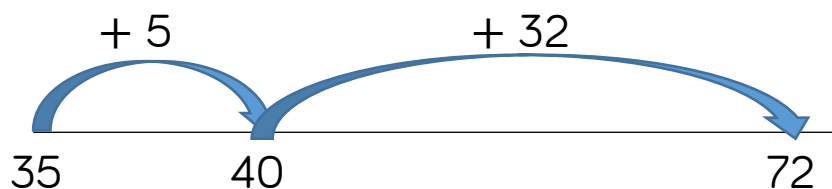

$$72 - 35 = 37$$

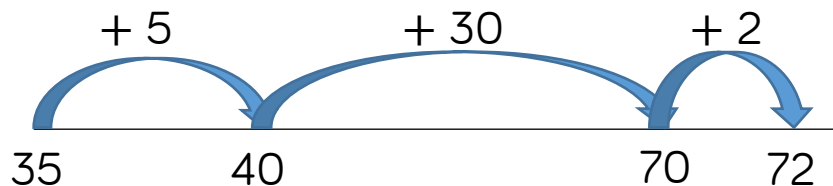

Benefits

Blank number lines provide children with a structure to add and subtract numbers in smaller parts.

Developing from labelled number lines, children can add by jumping to the nearest 10 and then adding the rest of the number either as a whole or by adding the tens and ones separately.

Children may also count back on a number line to subtract, again by jumping to the nearest 10 and then subtracting the rest of the number.

Blank number lines can also be used effectively to help children subtract by finding the difference between numbers. This can be done by starting with the smaller number and then counting on to the larger number. They then add up the parts they have counted on to find the difference between the numbers.

Straws

$$7 + 6 = 13$$

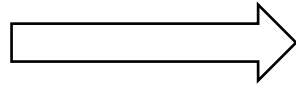
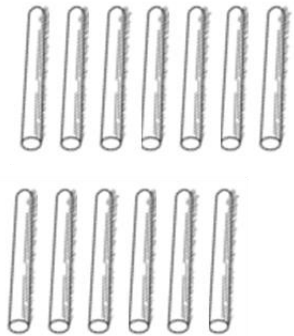

bundle together
groups of 10

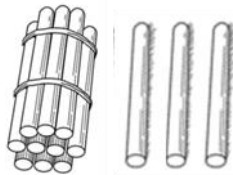

$$42 - 17 = 25$$

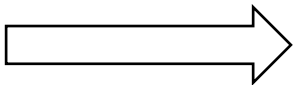
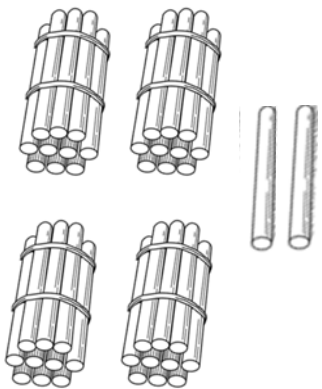

unbundle group
of 10 straws

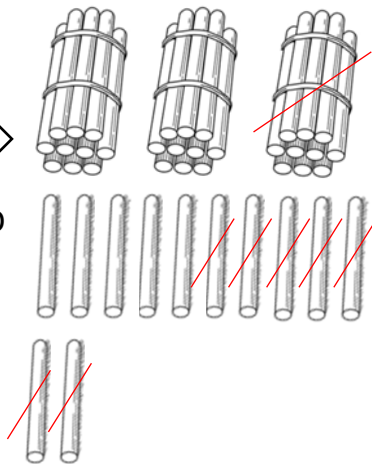

Benefits

Straws are an effective way to support children in their understanding of exchange when adding and subtracting 2-digit numbers.

Children can be introduced to the idea of bundling groups of ten when adding smaller numbers and when representing 2-digit numbers. Use elastic bands or other ties to make bundles of ten straws.

When adding numbers, children bundle a group of 10 straws to represent the exchange from 10 ones to 1 ten. They then add the individual straws (ones) and bundles of straws (tens) to find the total.

When subtracting numbers, children unbundle a group of 10 straws to represent the exchange from 1 ten to 10 ones.

Straws provide a good stepping stone to adding and subtracting with Base 10/Dienes.

Base 10/Dienes (addition)

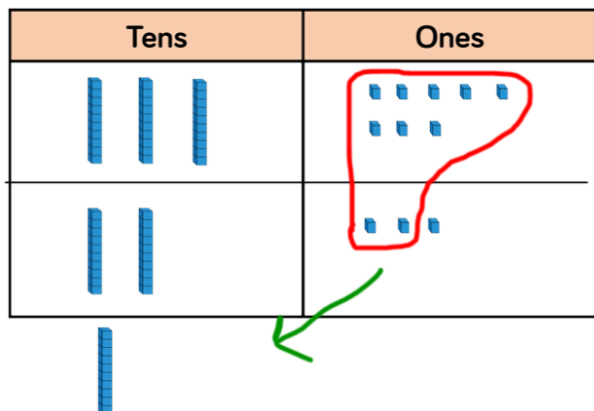

$$\begin{array}{r} 38 \\ + 23 \\ \hline 61 \\ \hline 1 \end{array}$$

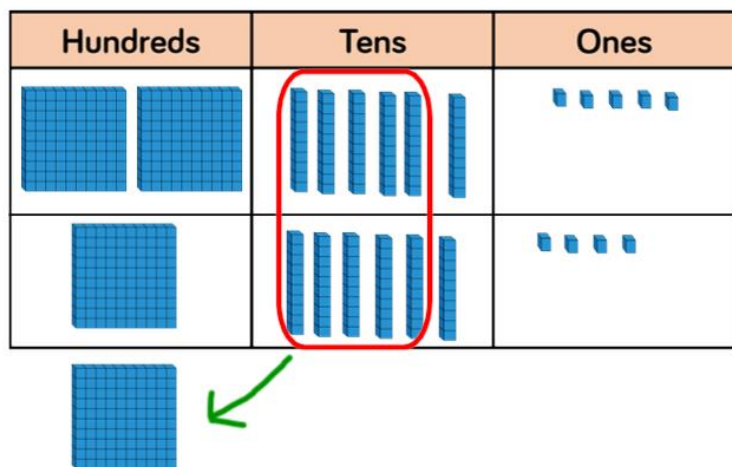

$$\begin{array}{r} 265 \\ + 164 \\ \hline 429 \\ \hline 1 \end{array}$$

Benefits

Using Base 10 or Dienes is an effective way to support children's understanding of column addition. It is important that children write out their calculations alongside using or drawing Base 10 so they can see the clear links between the written method and the model.

Children should first add without an exchange before moving on to addition with exchange. The representation becomes less efficient with larger numbers due to the size of Base 10. In this case, place value counters may be the better model to use.

When adding, always start with the smallest place value column. Here are some questions to support children.

- How many ones are there altogether?
- Can we make an exchange? (Yes or No)
- How many do we exchange? (10 ones for 1 ten, show exchanged 10 in tens column by writing 1 in column)
- How many ones do we have left? (Write in ones column)

Repeat for each column.

Base 10/Dienes (subtraction)

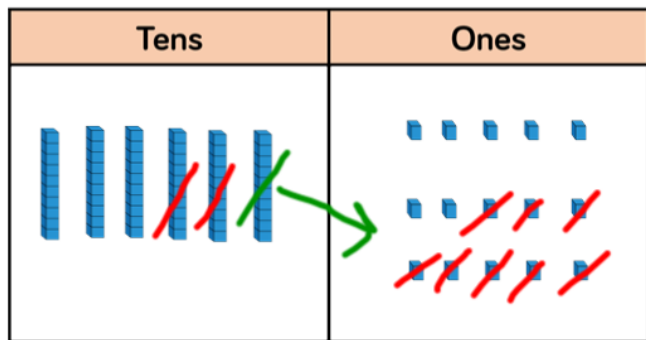

$$\begin{array}{r}
 \overset{5}{\cancel{6}} \overset{1}{\cancel{5}} \\
 - 28 \\
 \hline
 37 \\
 \hline
 \end{array}$$

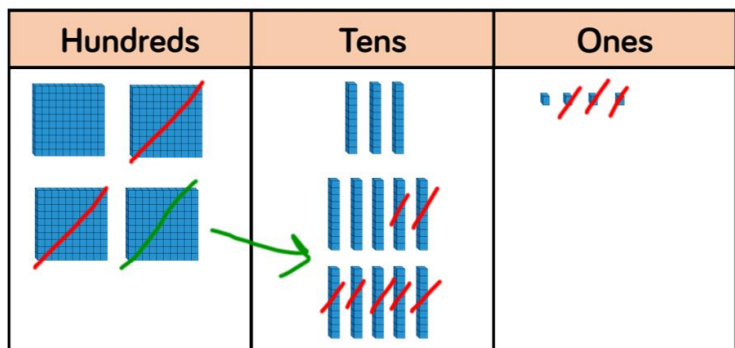

$$\begin{array}{r}
 \overset{3}{\cancel{4}} \overset{1}{\cancel{3}} 5 \\
 - 273 \\
 \hline
 162 \\
 \hline
 \end{array}$$

Benefits

Using Base 10 or Dienes is an effective way to support children's understanding of column subtraction. It is important that children write out their calculations alongside using or drawing Base 10 so they can see the clear links between the written method and the model.

Children should first subtract without an exchange before moving on to subtraction with exchange. When building the model, children should just make the minuend using Base 10, they then subtract the subtrahend. Highlight this difference to addition to avoid errors by making both numbers. Children start with the smallest place value column. When there are not enough ones/tens/hundreds to subtract in a column, children need to move to the column to the left and exchange e.g. exchange 1 ten for 10 ones. They can then subtract efficiently.

This model is efficient with up to 4-digit numbers. Place value counters are more efficient with larger numbers and decimals.

Place Value Counters (addition)

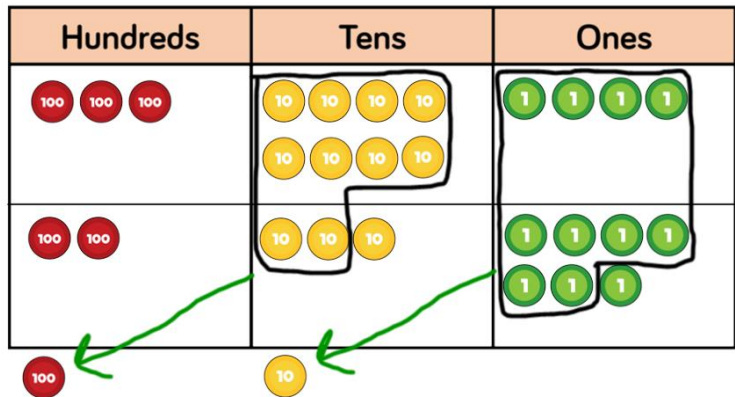

$$\begin{array}{r}
 384 \\
 + 237 \\
 \hline
 621 \\
 11
 \end{array}$$

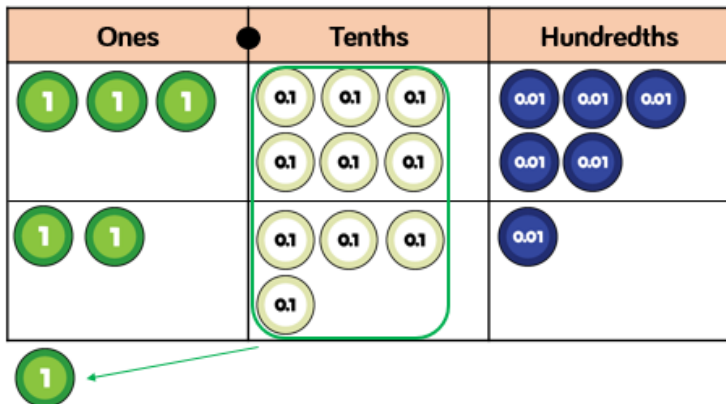

$$\begin{array}{r}
 3.65 \\
 + 2.41 \\
 \hline
 6.06 \\
 1
 \end{array}$$

Benefits

Using place value counters is an effective way to support children's understanding of column addition. It is important that children write out their calculations alongside using or drawing counters so they can see the clear links between the written method and the model.

Children should first add without an exchange before moving on to addition with exchange. Different place value counters can be used to represent larger numbers or decimals. If you don't have place value counters, use normal counters on a place value grid to enable children to experience the exchange between columns.

When adding money, children can also use coins to support their understanding. It is important that children consider how the coins link to the written calculation especially when adding decimal amounts.

Place Value Counters (Subtraction)

Hundreds	Tens	Ones

$$\begin{array}{r}
 \overset{4}{\cancel{6}}\overset{1}{\cancel{5}}2 \\
 - 207 \\
 \hline
 445 \\
 \hline
 \end{array}$$

Thousands	Hundreds	Tens	Ones

$$\begin{array}{r}
 \overset{3}{\cancel{4}}\overset{1}{\cancel{3}}57 \\
 - 2735 \\
 \hline
 1622 \\
 \hline
 \end{array}$$

Benefits

Using place value counters is an effective way to support children's understanding of column subtraction. It is important that children write out their calculations alongside using or drawing counters so they can see the clear links between the written method and the model.

Children should first subtract without an exchange before moving on to subtraction with exchange. If you don't have place value counters, use normal counters on a place value grid to enable children to experience the exchange between columns.

When building the model, children should just make the minuend using counters, they then subtract the subtrahend. Children start with the smallest place value column. When there are not enough ones/tens/hundreds to subtract in a column, children need to move to the column to the left and exchange e.g. exchange 1 ten for 10 ones. They can then subtract efficiently.

Addition

Skill	Year	Representations and models	
Add two 1-digit numbers to 10	1	Part-whole model Bar model Number shapes	Ten frames (within 10) Bead strings (10) Number tracks
Add 1 and 2-digit numbers to 20	1	Part-whole model Bar model Number shapes Ten frames (within 20)	Bead strings (20) Number tracks Number lines (labelled) Straws
Add three 1-digit numbers	2	Part-whole model Bar model	Ten frames (within 20) Number shapes
Add 1 and 2-digit numbers to 100	2	Part-whole model Bar model Number lines (labelled)	Number lines (blank) Straws Hundred square

Skill	Year	Representations and models	
Add two 2-digit numbers	2	Part-whole model Bar model Number lines (blank) Straws	Base 10 Place value counters
Add with up to 3-digits	3	Part-whole model Bar model	Base 10 Place value counters Column addition
Add with up to 4-digits	4	Part-whole model Bar model	Base 10 Place value counters Column addition
Add with more than 4 digits	5	Part-whole model Bar model	Place value counters Column addition
Add with up to 3 decimal places	5	Part-whole model Bar model	Place value counters Column addition

Skill: Add 1-digit numbers within 10

Year: 1

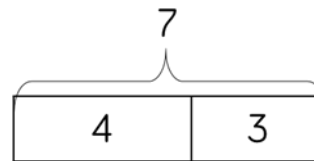
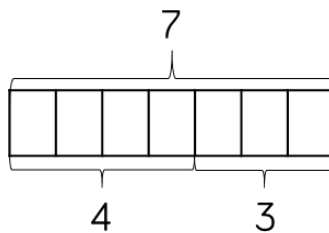
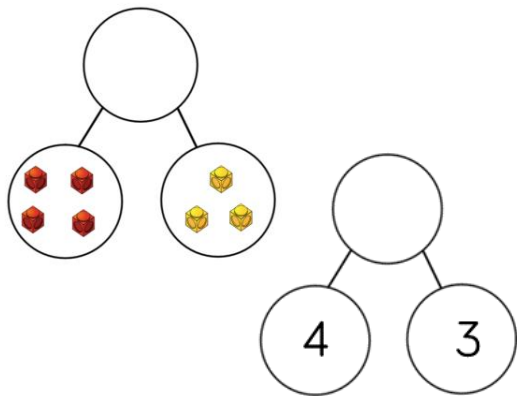

$$4 + 3 = 7$$

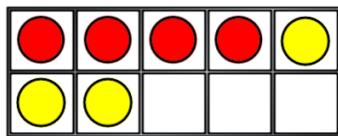
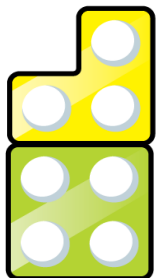
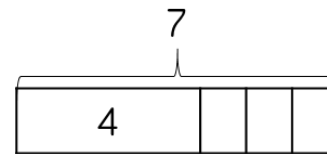

When adding numbers to 10, children can explore both aggregation and augmentation.

The part-whole model, discrete and continuous bar model, number shapes and ten frame support aggregation.

The combination bar model, ten frame, bead string and number track all support augmentation.

Skill: Add 1 and 2-digit numbers to 20

Year: 1/2

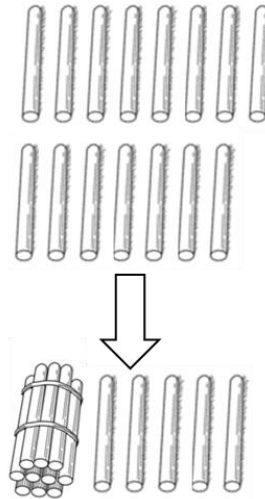
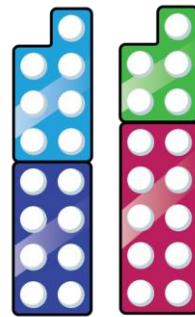
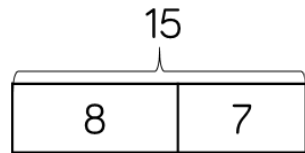
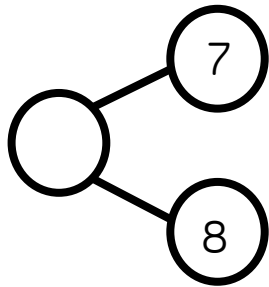

$$8 + 7 = 15$$

$$8 + 7 = 15$$

2 5

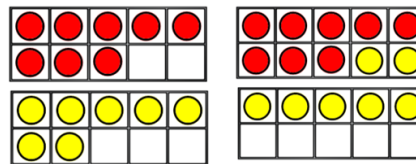
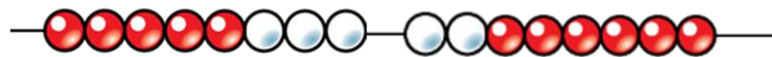
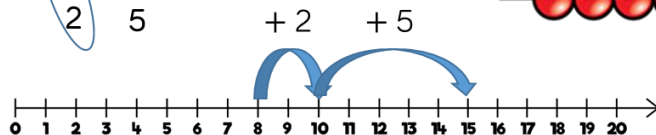

$$8 + 7 = 15$$

2 5

When adding one-digit numbers that cross 10, it is important to highlight the importance of ten ones equalling one ten. In Year 1, this is only done just by counting on. From Year 2, use different manipulatives can be used to represent this exchange alongside number lines to support children in understanding how to partition their jumps.

Skill: Add three 1-digit numbers

Year: 2

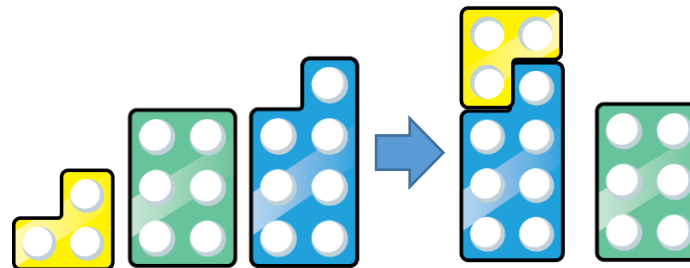
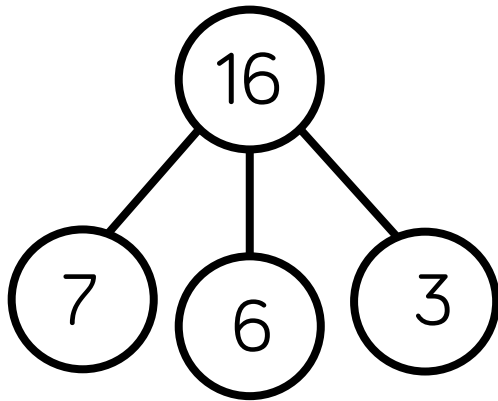

$$7 + 6 + 3 = 16$$

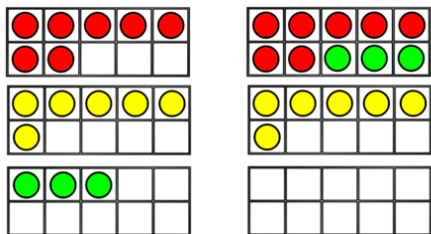

$$7 + 6 + 3 = 16$$

10

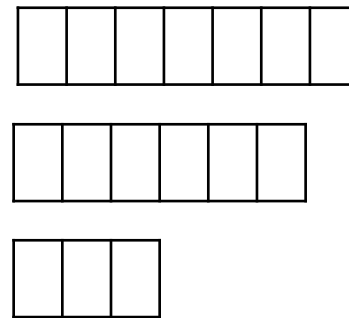

16

When adding three 1-digit numbers, children should be encouraged to look for number bonds to 10 or doubles to add the numbers more efficiently.

This supports children in their understanding of commutativity.

Manipulatives that highlight number bonds to 10 are effective when adding three 1-digit numbers.

Skill: Add 1-digit and 2-digit numbers to 100

Year: 2/3

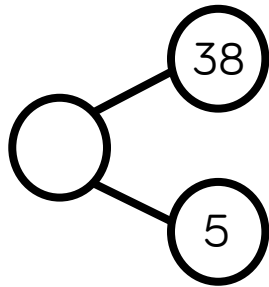

?

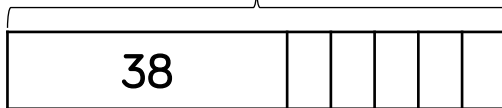
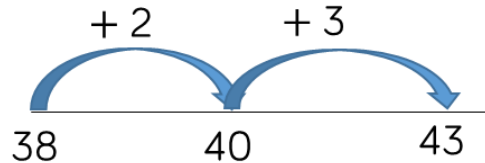
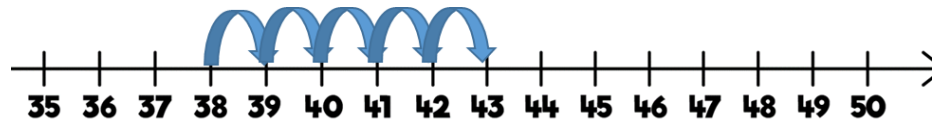

$$38 + 5 = 43$$

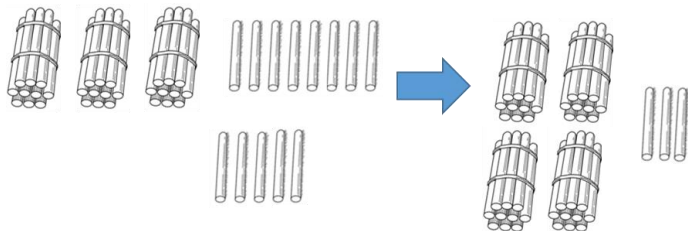

1	2	3	4	5	6	7	8	9	10
11	12	13	14	15	16	17	18	19	20
21	22	23	24	25	26	27	28	29	30
31	32	33	34	35	36	37	38	39	40
41	42	43	44	45	46	47	48	49	50
51	52	53	54	55	56	57	58	59	60
61	62	63	64	65	66	67	68	69	70
71	72	73	74	75	76	77	78	79	80
81	82	83	84	85	86	87	88	89	90
91	92	93	94	95	96	97	98	99	100

When adding single digits to a two-digit number, children should be encouraged to count on from the larger number.

They should also apply their knowledge of number bonds to add more efficiently e.g. $8 + 5 = 13$ so $38 + 5 = 43$.

Hundred squares and straws can support children to find the number bond to 10.

Skill: Add two 2-digit numbers to 100

Year: 2/3

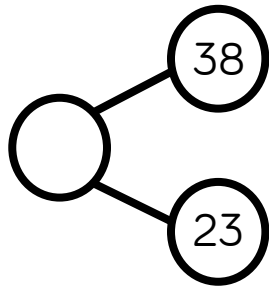

?

38	23
----	----

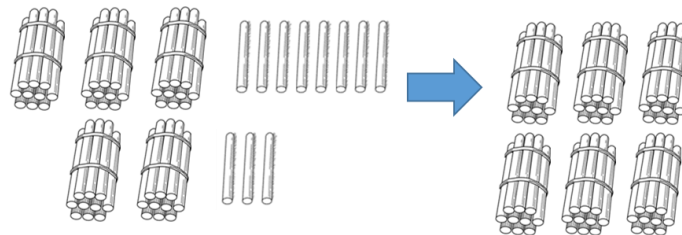
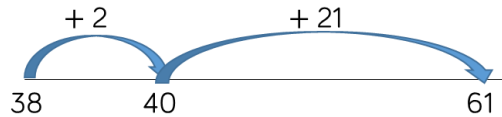

$$38 + 23 = 61$$

Tens	Ones

$$\begin{array}{r} 38 \\ + 23 \\ \hline 61 \\ 1 \end{array}$$

Tens	Ones

Children can use a blank number line and other representations to count on to find the total. Encourage them to jump to multiples of 10 to become more efficient. From Year 3, encourage children to use the formal column method when calculating alongside straws, base 10 or place value counters. As numbers become larger, straws become less efficient.

Skill: Add numbers with up to 3 digits

Year: 3

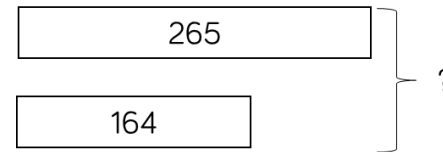
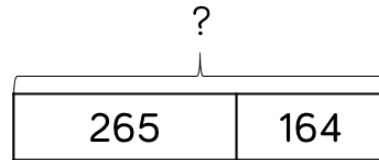
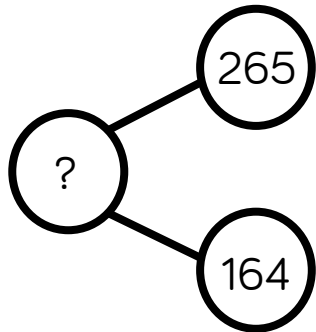

$$265 + 164 = 429$$

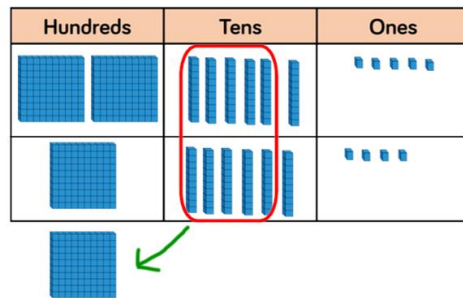

$$\begin{array}{r} 265 \\ + 164 \\ \hline 429 \\ \hline 1 \end{array}$$

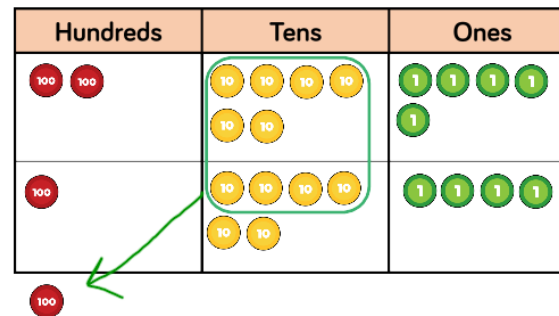

Base 10 and place value counters are the most effective manipulatives when adding numbers with up to 3 digits.

Ensure children write out their calculation alongside any concrete resources so they can see the links to the written column method.

Plain counters on a place value grid can also be used to support learning.

Skill: Add numbers with up to 4 digits

Year: 4

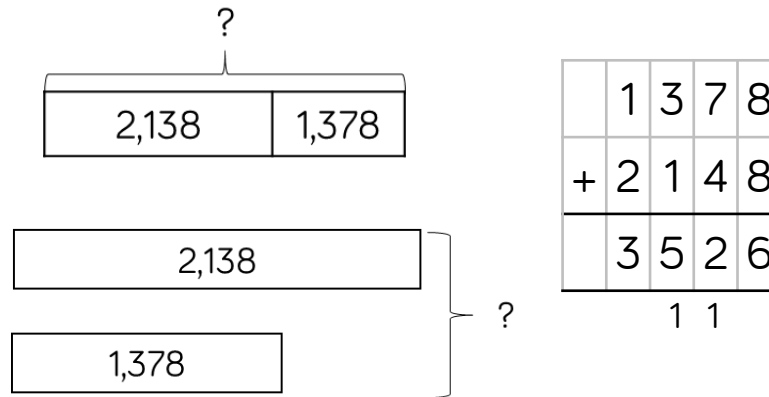
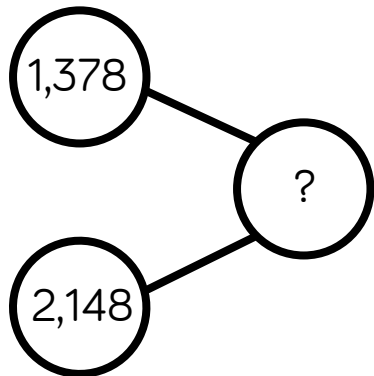

$$1,378 + 2,148 = 3,526$$

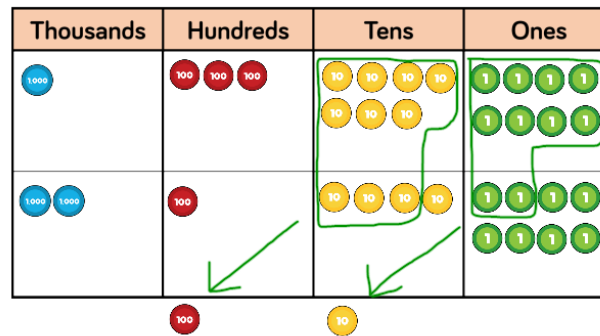
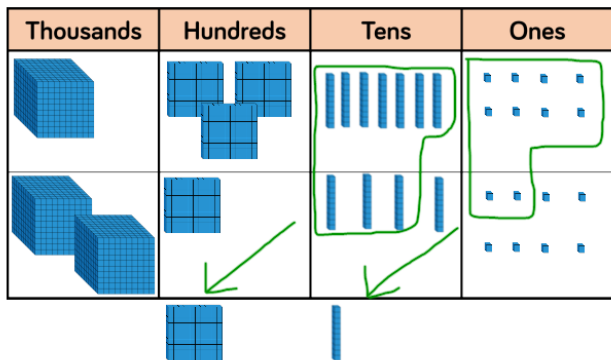

Base 10 and place value counters are the most effective manipulatives when adding numbers with up to 4 digits.

Ensure children write out their calculation alongside any concrete resources so they can see the links to the written column method.

Plain counters on a place value grid can also be used to support learning.

Skill: Add numbers with more than 4 digits

Year: 5/6

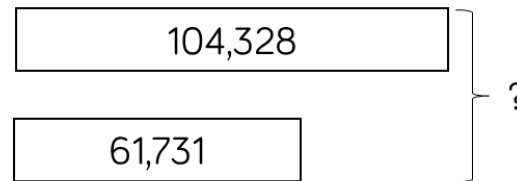
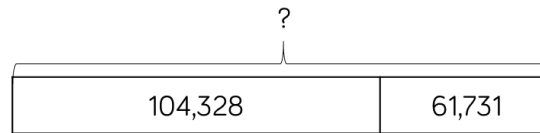
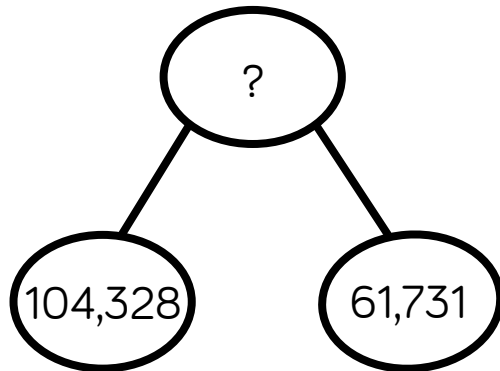

$$104,328 + 61,731 = 166,059$$

HTh	TTh	Th	H	T	O
100000		1000 1000 1000 1000	100 100 100	10 10	1 1 1 1 1 1 1 1
	10000 10000 10000 10000 10000 10000	1000	100 100 100 100 100 100 100	10 10 10	1

1	0	4	3	2	8
+	6	1	7	3	1
1	6	6	0	5	9
					1

Place value counters or plain counters on a place value grid are the most effective concrete resources when adding numbers with more than 4 digits.

At this stage, children should be encouraged to work in the abstract, using the column method to add larger numbers efficiently.

Skill: Add with up to 3 decimal places

Year: 5

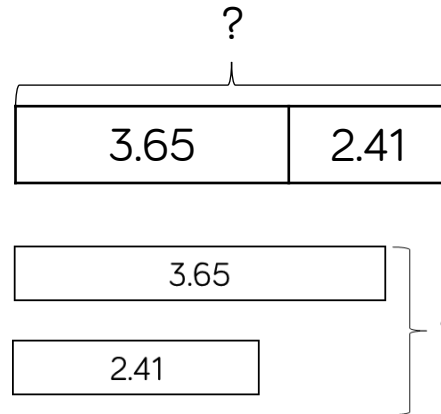
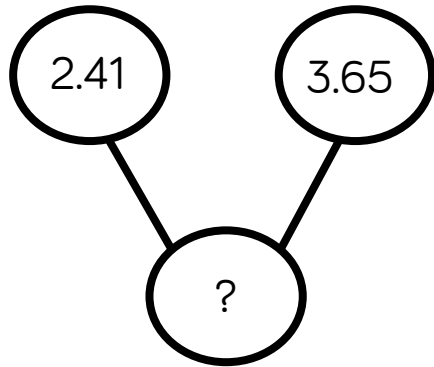

$$\begin{array}{r} 3.65 \\ + 2.41 \\ \hline 6.06 \\ 1 \end{array}$$

$$3.65 + 2.41 = 6.06$$

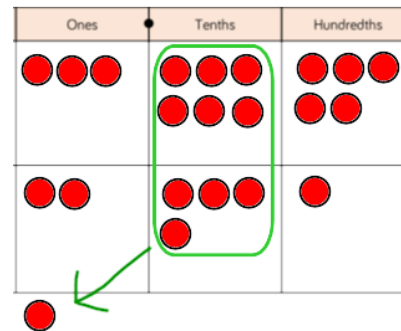
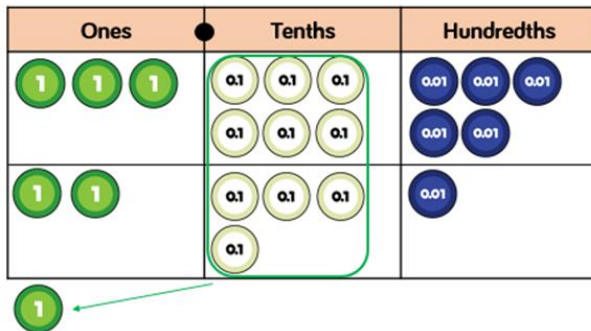

Place value counters and plain counters on a place value grid are the most effective manipulatives when adding decimals with 1, 2 and then 3 decimal places.

Ensure children have experience of adding decimals with a variety of decimal places. This includes putting this into context when adding money and other measures.

Subtraction

Skill	Year	Representations and models	
Subtract two 1-digit numbers to 10	1	Part-whole model Bar model Number shapes	Ten frames (within 10) Bead strings (10) Number tracks
Subtract 1 and 2-digit numbers to 20	1	Part-whole model Bar model Number shapes Ten frames (within 20)	Bead string (20) Number tracks Number lines (labelled) Straws
Subtract 1 and 2-digit numbers to 100	2	Part-whole model Bar model Number lines (labelled)	Number lines (blank) Straws Hundred square
Subtract two 2-digit numbers	2	Part-whole model Bar model Number lines (blank) Straws	Base 10 Place value counters

Skill	Year	Representations and models	
Subtract with up to 3-digits	3	Part-whole model Bar model	Base 10 Place value counters Column subtraction
Subtract with up to 4-digits	4	Part-whole model Bar model	Base 10 Place value counters Column subtraction
Subtract with more than 4 digits	5	Part-whole model Bar model	Place value counters Column subtraction
Subtract with up to 3 decimal places	5	Part-whole model Bar model	Place value counters Column subtraction

Skill: Subtract 1-digit numbers within 10

Year: 1

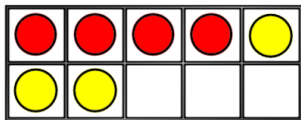
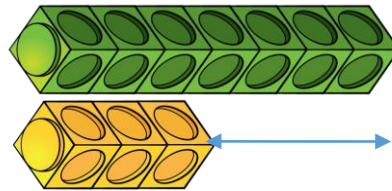
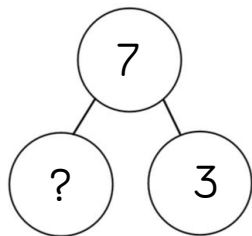

$$7 - 3 = 4$$

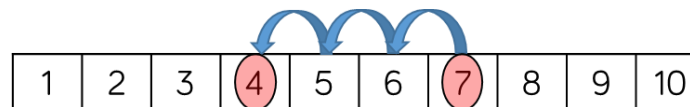
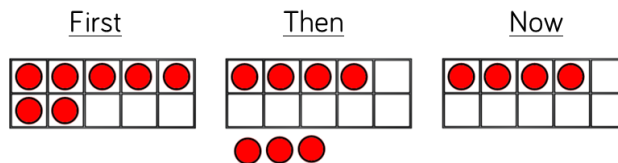
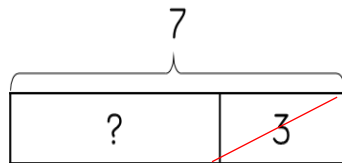
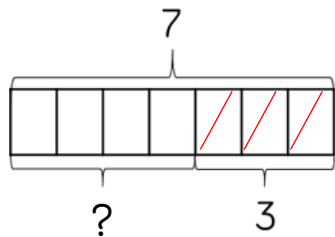

Part-whole models, bar models, ten frames and number shapes support partitioning.

Ten frames, number tracks, single bar models and bead strings support reduction.

Cubes and bar models with two bars can support finding the difference.

Skill: Subtract 1 and 2-digit numbers to 20

Year: 1/2

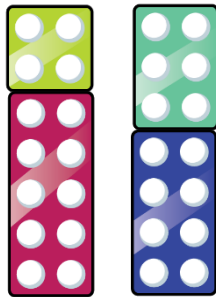
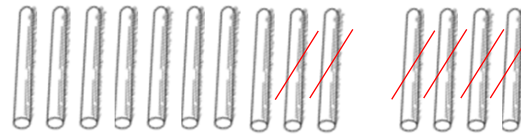
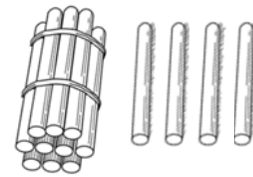
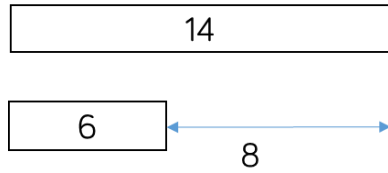
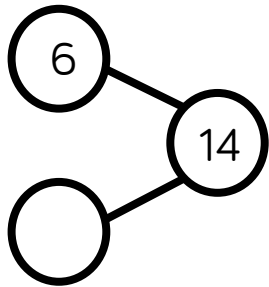

$$14 - 6 = 8$$

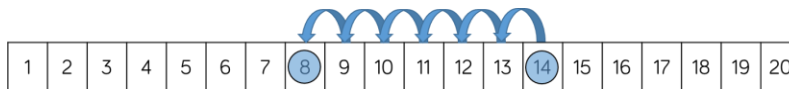

$$14 - 6 = 8$$

A diagram showing the number 14 circled in blue. A line from 14 goes down to 4, and another line goes right to 2. The number 8 is written to the right.

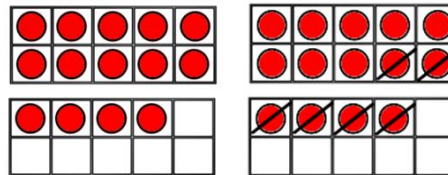
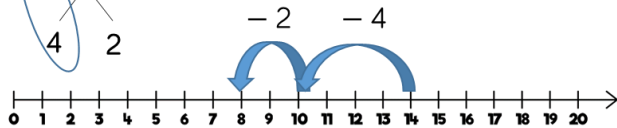

$$14 - 6 = 8$$

A diagram showing the number 14 circled in blue. A line from 14 goes down to 4, and another line goes right to 2. The number 8 is written to the right.

In Year 1, subtracting one-digit numbers that cross 10, is done by counting back, using objects, number tracks and number lines. From Year 2, children should be encouraged to find the number bond to 10 when partitioning the subtracted number. Ten frames, number shapes and number lines are particularly useful for this.

Skill: Subtract 1 and 2-digit numbers to 100

Year: 2/3

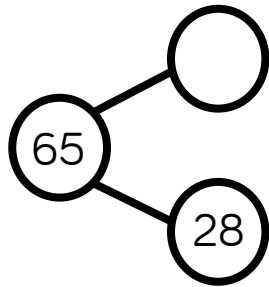

65

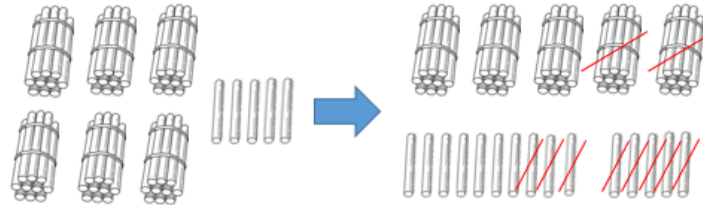
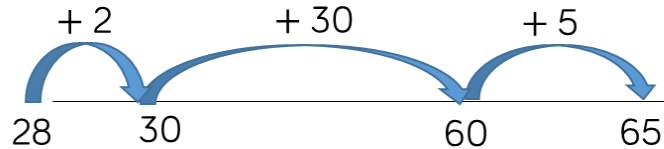
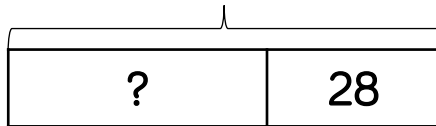

$$65 - 28 = 37$$

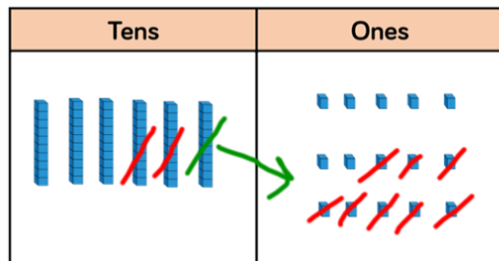

$$\begin{array}{r} 5 \ 1 \\ 65 \\ - 28 \\ \hline 37 \end{array}$$

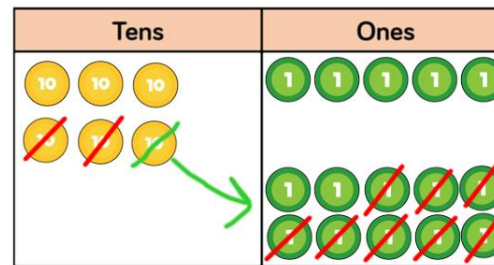

Children can also use a blank number line to count back to find the difference.

Encourage them to jump to multiples of 10 to become more efficient.

From Year 3, encourage children to use the formal column method when calculating alongside straws, base 10 or place value counters. As numbers become larger, straws become less efficient.

Skill: Subtract numbers with up to 3 digits

Year: 3

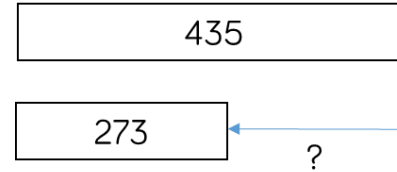
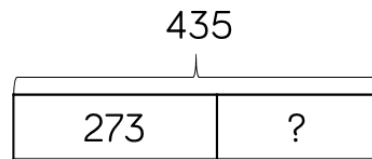
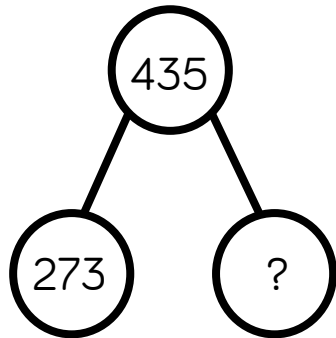

$$435 - 273 = 162$$

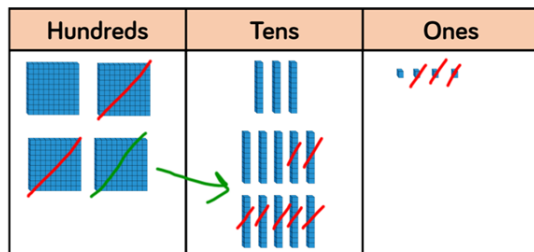

$$\begin{array}{r} 3 \quad 1 \\ 435 \\ - 273 \\ \hline 162 \end{array}$$

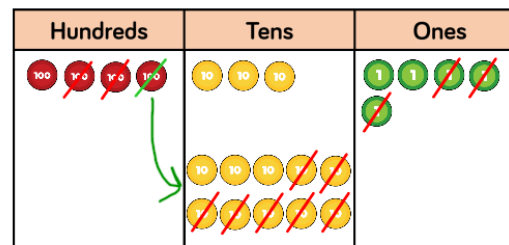

Base 10 and place value counters are the most effective manipulative when subtracting numbers with up to 3 digits.

Ensure children write out their calculation alongside any concrete resources so they can see the links to the written column method.

Plain counters on a place value grid can also be used to support learning.

Skill: Subtract numbers with up to 4 digits

Year: 4

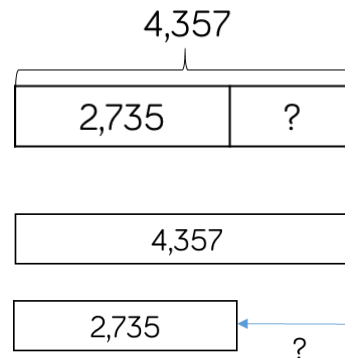
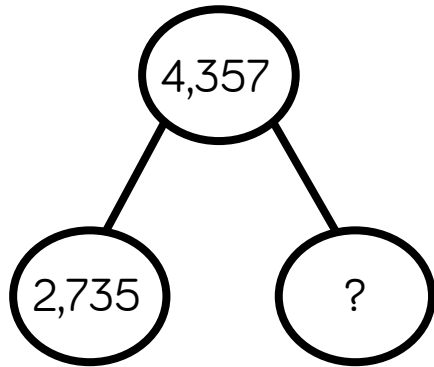

$$\begin{array}{r} \overset{3}{\cancel{4}} \overset{1}{3} 57 \\ - 2735 \\ \hline 1622 \end{array}$$

$$4,357 - 2,735 = 1,622$$

Thousands	Hundreds	Tens	Ones

Thousands	Hundreds	Tens	Ones

Base 10 and place value counters are the most effective manipulatives when subtracting numbers with up to 4 digits.

Ensure children write out their calculation alongside any concrete resources so they can see the links to the written column method.

Plain counters on a place value grid can also be used to support learning.

Skill: Subtract numbers with more than 4 digits

Year: 5/6

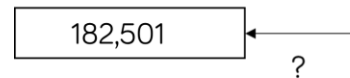
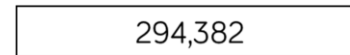
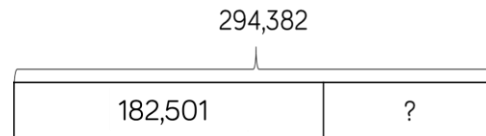
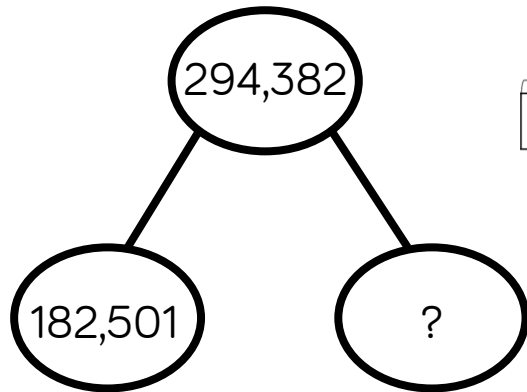

$$294,382 - 182,501 = 111,881$$

HTh	TTh	Th	H	T	O
100,000 (1), 100,000 (1) 	10,000 (3), 10,000 (3), 10,000 (3) 	1,000 (1), 1,000 (1), 1,000 (1) 	100 (3), 100 (3), 100 (3)	10 (3), 10 (3), 10 (3)	1 (1), 1 (1)
		1,000 (1) 	100 (3), 100 (3), 100 (3)	10 (3), 10 (3)	
			100 (3), 100 (3), 100 (3)		
			10 (3), 10 (3), 10 (3)		
			10 (3)		

	2	9	3	1 3	8	2
-	1	8	2	5	0	1
	1	1	1	8	8	1

Place value counters or plain counters on a place value grid are the most effective concrete resource when subtracting numbers with more than 4 digits.

At this stage, children should be encouraged to work in the abstract, using column method to subtract larger numbers efficiently.

Skill: Subtract with up to 3 decimal places

Year: 5/6

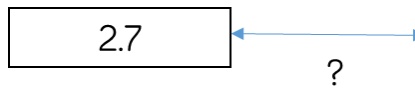
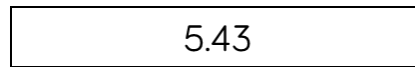
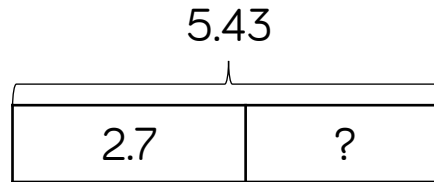
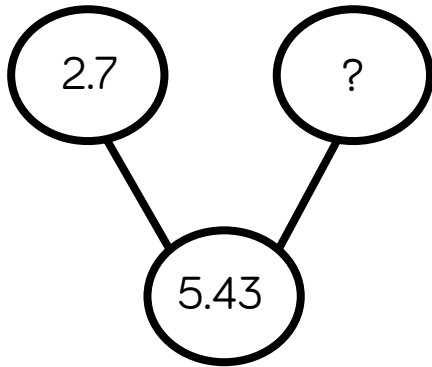

$$\begin{array}{r}
 \overset{4}{5}.\overset{1}{4}3 \\
 - 2.7 \\
 \hline
 2.73
 \end{array}$$

$$5.43 - 2.7 = 2.73$$

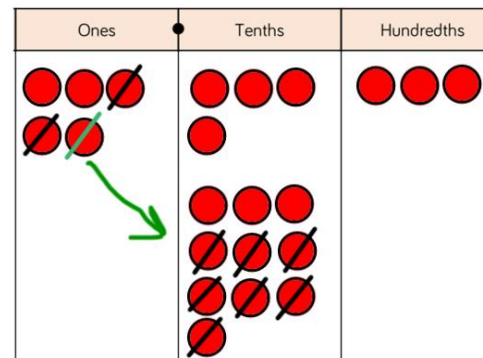
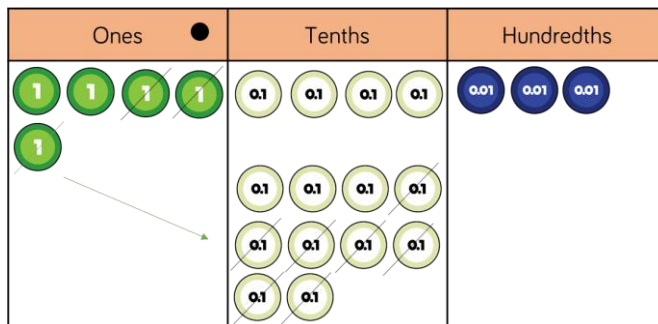

Place value counters and plain counters on a place value grid are the most effective manipulative when subtracting decimals with 1, 2 and then 3 decimal places.

Ensure children have experience of subtracting decimals with a variety of decimal places. This includes putting this into context when subtracting money and other measures.

Glossary

Addend - A number to be added to another.

Aggregation - combining two or more quantities or measures to find a total.

Augmentation - increasing a quantity or measure by another quantity.

Commutative - numbers can be added in any order.

Complement - in addition, a number and its complement make a total e.g. 300 is the complement to 700 to make 1,000

Difference - the numerical difference between two numbers is found by comparing the quantity in each group.

Exchange - Change a number or expression for another of an equal value.

Minuend - A quantity or number from which another is subtracted.

Partitioning - Splitting a number into its component parts.

Reduction - Subtraction as take away.

Subitise - Instantly recognise the number of objects in a small group without needing to count.

Subtrahend - A number to be subtracted from another.

Sum - The result of an addition.

Total - The aggregate or the sum found by addition.

Year 1 - 6

Calculation Policy

Multiplication and Division

[#MathsEveryoneCan](#)



Calculation Policy

Welcome to the White Rose Maths Calculation Policy.

This document is broken down into addition and subtraction, and multiplication and division.

At the start of each policy, there is an overview of the different models and images that can support the teaching of different concepts. These provide explanations of the benefits of using the models and show the links between different operations.

Each operation is then broken down into skills and each skill has a dedicated page showing the different models and images that could be used to effectively teach that concept.

Place Value Counters (Multiplication)

Hundreds	Tens	Ones
	3	4
	0	5
	1	2

$$\begin{array}{r} 34 \\ \times 5 \\ \hline 120 \\ 12 \end{array}$$

Benefits

Using place value counters is an effective way to support children's understanding of column multiplication. It is important that children write out their calculation alongside the equipment so they can see how the concrete and written match.

As numbers become larger in multiplication or the amounts of groups becomes higher, Base 10 / Dienes becomes less efficient due to the amount of equipment and number of exchanges needed. The counters should be used to support the understanding of the written method rather than support the arithmetic.

Place Value counters also support the area model of multiplication well. Children can see how to multiply 2-digit numbers by 2-digit numbers.

Hundreds	Tens	Ones
	4	4
	0	2
	1	2

$$\begin{array}{r} 44 \\ \times 32 \\ \hline 8 \\ 80 \\ 120 \\ + 1200 \\ \hline 1408 \\ 1 \end{array}$$

Skill: Multiply 2-digit numbers by 1-digit numbers

Year: 3/4

Hundreds	Tens	Ones
	3	4
	0	5
	1	2

$$34 \times 5 = 170$$

H	T	O
	3	4
x		5
	2	0
	1	7
	1	7
	1	7

Teachers may decide to first look at the expanded column method before moving on to the short multiplication method.

The place value counters should be used to support the understanding of the method rather than supporting the multiplication as children should use times table knowledge.

There is an overview of skills linked to year groups to support consistency through out school. A glossary of terms is provided at the end of the calculation policy to support understanding of the key language used to teach the four operations.

Bar Model

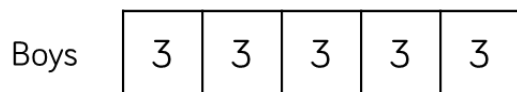
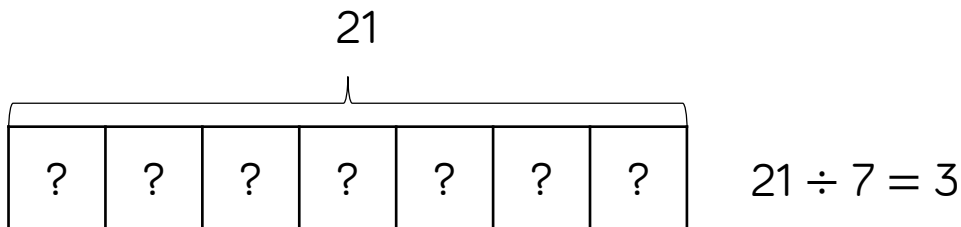
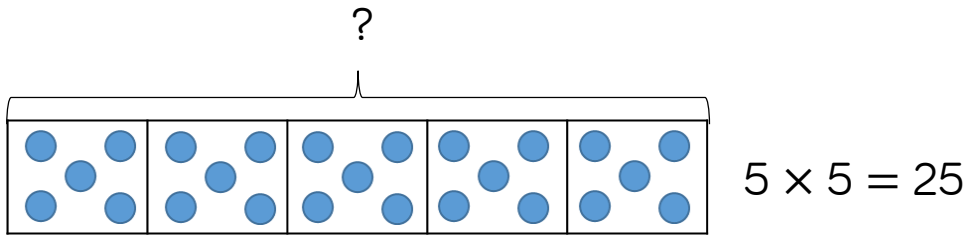

Benefits

Children can use the single bar model to represent multiplication as repeated addition. They could use counters, cubes or dots within the bar model to support calculation before moving on to placing digits into the bar model to represent the multiplication.

Division can be represented by showing the total of the bar model and then dividing the bar model into equal groups.

It is important when solving word problems that the bar model represents the problem.

Sometimes, children may look at scaling problems. In this case, more than one bar model is useful to represent this type of problem, e.g. There are 3 girls in a group. There are 5 times more boys than girls. How many boys are there?

The multiple bar model provides an opportunity to compare the groups.

Number Shapes



$$5 \times 4 = 20$$

$$4 \times 5 = 20$$

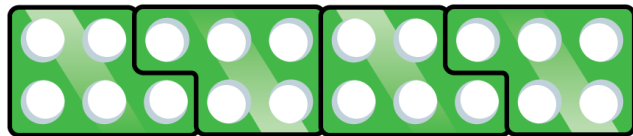

$$5 \times 4 = 20$$

$$4 \times 5 = 20$$

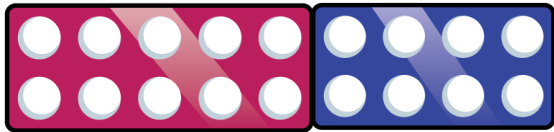

$$18 \div 3 = 6$$

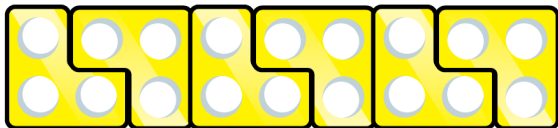

Benefits

Number shapes support children's understanding of multiplication as repeated addition.

Children can build multiplications in a row using the number shapes. When using odd numbers, encourage children to interlock the shapes so there are no gaps in the row. They can then use the tens number shapes along with other necessary shapes over the top of the row to check the total. Using the number shapes in multiplication can support children in discovering patterns of multiplication e.g. odd \times odd = even, odd \times even = odd, even \times even = even.

When dividing, number shapes support children's understanding of division as grouping. Children make the number they are dividing and then place the number shape they are dividing by over the top of the number to find how many groups of the number there are altogether e.g. There are 6 groups of 3 in 18.

Bead Strings



$$5 \times 3 = 15$$

$$3 \times 5 = 15$$

$$15 \div 3 = 5$$



$$5 \times 3 = 15$$

$$3 \times 5 = 15$$

$$15 \div 5 = 3$$



$$4 \times 5 = 20$$

$$5 \times 4 = 20$$

$$20 \div 4 = 5$$

Benefits

Bead strings to 100 can support children in their understanding of multiplication as repeated addition. Children can build the multiplication using the beads. The colour of beads supports children in seeing how many groups of 10 they have, to calculate the total more efficiently.

Encourage children to count in multiples as they build the number e.g. 4, 8, 12, 16, 20.

Children can also use the bead string to count forwards and backwards in multiples, moving the beads as they count.

When dividing, children build the number they are dividing and then group the beads into the number they are dividing by e.g. 20 divided by 4 - Make 20 and then group the beads into groups of four. Count how many groups you have made to find the answer.

Number Tracks

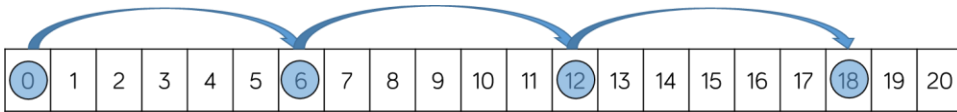
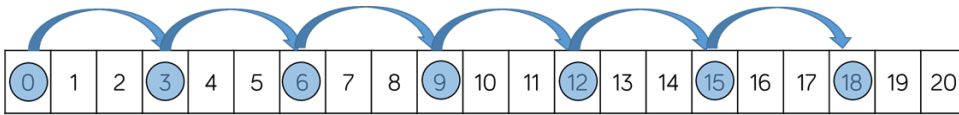

$$6 \times 3 = 18$$

$$3 \times 6 = 18$$

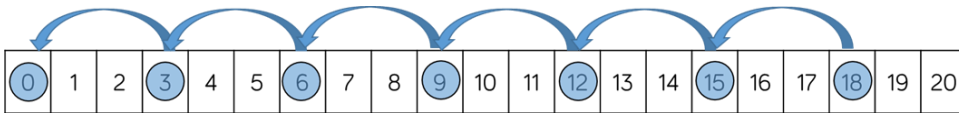

$$18 \div 3 = 6$$

Benefits

Number tracks are useful to support children to count in multiples, forwards and backwards. Moving counters or cubes along the number track can support children to keep track of their counting. Translucent counters help children to see the number they have landed on whilst counting.

When multiplying, children place their counter on 0 to start and then count on to find the product of the numbers.

When dividing, children place their counter on the number they are dividing and the count back in jumps of the number they are dividing by until they reach 0. Children record how many jumps they have made to find the answer to the division.

Number tracks can be useful with smaller multiples but when reaching larger numbers they can become less efficient.

Number Lines (labelled)

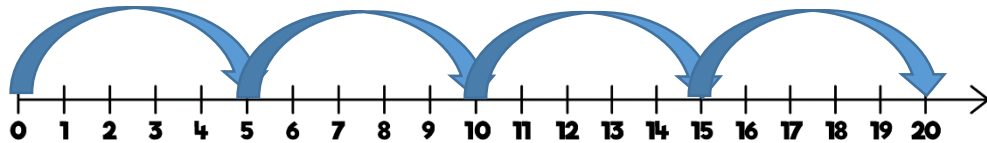
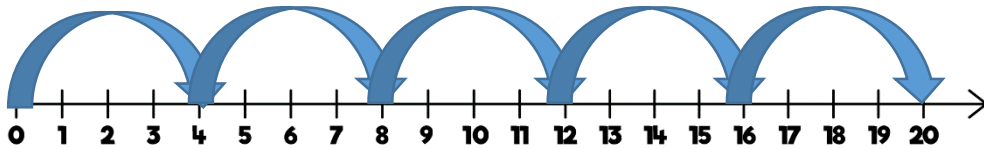

$$4 \times 5 = 20$$

$$5 \times 4 = 20$$

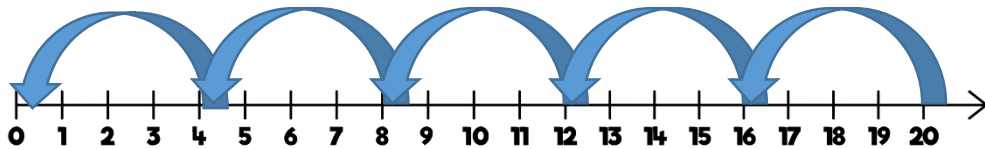

$$20 \div 4 = 5$$

Benefits

Labelled number lines are useful to support children to count in multiples, forwards and backwards as well as calculating single-digit multiplications.

When multiplying, children start at 0 and then count on to find the product of the numbers.

When dividing, start at the number they are dividing and the count back in jumps of the number they are dividing by until they reach 0.

Children record how many jumps they have made to find the answer to the division.

Labelled number lines can be useful with smaller multiples, however they become inefficient as numbers become larger due to the required size of the number line.

Number Lines (blank)

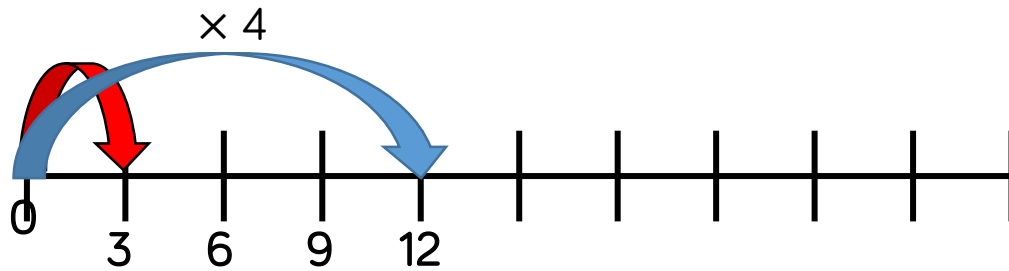

A red car travels 3 miles.

A blue car 4 times further.

How far does the blue car travel?

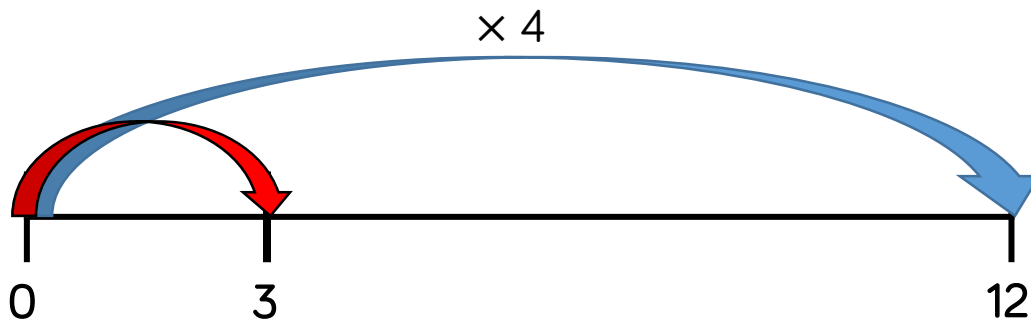

A blue car travels 12 miles.

A red car 4 times less.

How far does the red car travel?

Benefits

Children can use blank number lines to represent scaling as multiplication or division.

Blank number lines with intervals can support children to represent scaling accurately. Children can label intervals with multiples to calculate scaling problems.

Blank number lines without intervals can also be used for children to represent scaling.

Base 10/Dienes (multiplication)

Hundreds	Tens	Ones
		□□□□
		□□□□
		□□□□

$$\begin{array}{r}
 24 \\
 \times 3 \\
 \hline
 72 \\
 \hline
 1
 \end{array}$$

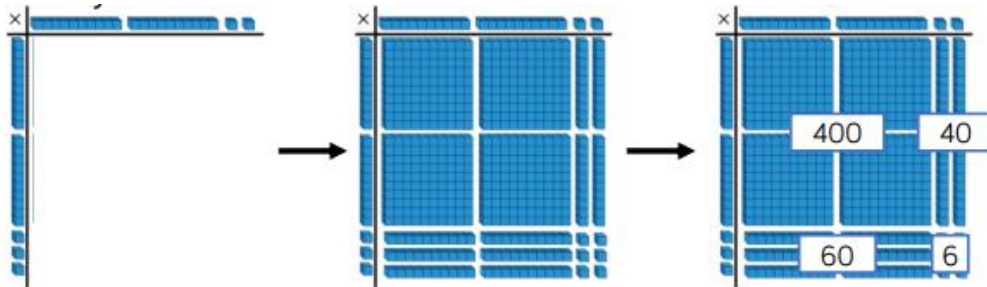

Benefits

Using Base 10 or Dienes is an effective way to support children's understanding of column multiplication. It is important that children write out their calculation alongside the equipment so they can see how the concrete and written representations match.

As numbers become larger in multiplication or the amounts of groups becomes higher, Base 10 / Dienes becomes less efficient due to the amount of equipment and number of exchanges needed.

Base 10 also supports the area model of multiplication well. Children use the equipment to build the number in a rectangular shape which they then find the area of by calculating the total value of the pieces. This area model can be linked to the grid method or the formal column method of multiplying 2-digits by 2-digits.

Base 10/Dienes (division)

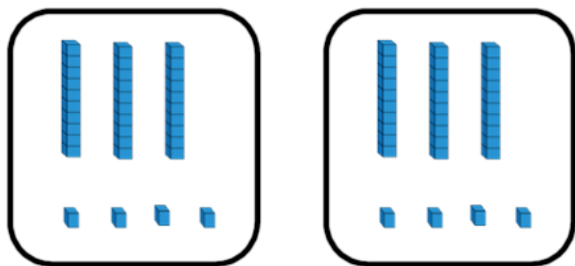

$$68 \div 2 = 34$$



Tens	Ones

$$72 \div 3 = 24$$

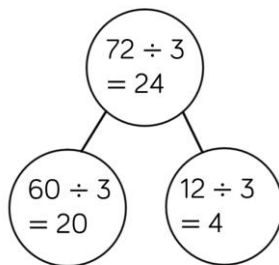

Benefits

Using Base 10 or Dienes is an effective way to support children's understanding of division.

When numbers become larger, it can be an effective way to move children from representing numbers as ones towards representing them as tens and ones in order to divide. Children can then share the Base 10/ Dienes between different groups e.g. by drawing circles or by rows on a place value grid.

When they are sharing, children start with the larger place value and work from left to right. If there are any left in a column, they exchange e.g. one ten for ten ones. When recording, encourage children to use the part-whole model so they can consider how the number has been partitioned in order to divide. This will support them with mental methods.

Place Value Counters (multiplication)



$$\begin{array}{r}
 34 \\
 \times 5 \\
 \hline
 170 \\
 \hline
 1 \ 2
 \end{array}$$

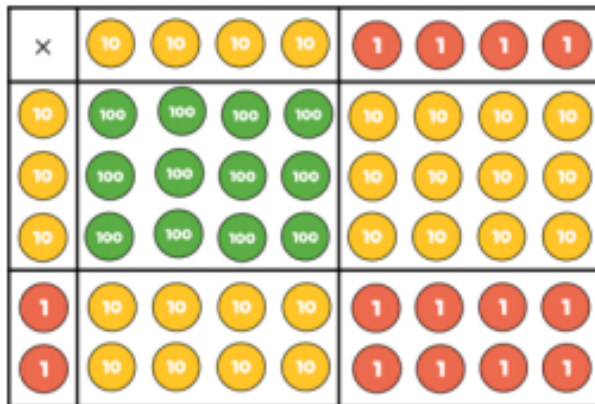

$$\begin{array}{r}
 44 \\
 \times 32 \\
 \hline
 88 \\
 800 \\
 1200 \\
 \hline
 1408 \\
 \hline
 1
 \end{array}$$

Benefits

Using place value counters is an effective way to support children's understanding of column multiplication. It is important that children write out their calculation alongside the equipment so they can see how the concrete and written match.

As numbers become larger in multiplication or the amounts of groups becomes higher, Base 10 / Dienes becomes less efficient due to the amount of equipment and number of exchanges needed. The counters should be used to support the understanding of the written method rather than support the arithmetic.

Place value counters also support the area model of multiplication well. Children can see how to multiply 2-digit numbers by 2-digit numbers.

Place Value Counters (division)

Tens	Ones
10 10	1 1 1 1
10 10	1 1 1 1
10 10	1 1 1 1
10 10	1 1 1 1

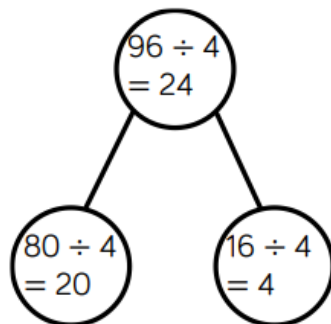

Thousands	Hundreds	Tens	Ones
1000 1000 1000 1000	100 100 100 100 100 100	10 10 10 10 10 10 10	1 1 1 1 1 1 1 1 1 1

$$\begin{array}{r}
 1223 \\
 4 \overline{) 4892}
 \end{array}$$

Benefits

Using place value counters is an effective way to support children's understanding of division.

When working with smaller numbers, children can use place value counters to share between groups. They start by sharing the larger place value column and work from left to right. If there are any counters left over once they have been shared, they exchange the counter e.g. exchange one ten for ten ones. This method can be linked to the part-whole model to support children to show their thinking.

Place value counters also support children's understanding of short division by grouping the counters rather than sharing them. Children work from left to right through the place value columns and group the counters in the number they are dividing by. If there are any counters left over after they have been grouped, they exchange the counter e.g. exchange one hundred for ten tens.

Times Tables

Skill	Year	Representations and models	
Recall and use multiplication and division facts for the 2-times table	2	Bar model Number shapes Counters Money	Ten frames Bead strings Number lines Everyday objects
Recall and use multiplication and division facts for the 5-times table	2	Bar model Number shapes Counters Money	Ten frames Bead strings Number lines Everyday objects
Recall and use multiplication and division facts for the 10-times table	2	Hundred square Number shapes Counters Money	Ten frames Bead strings Number lines Base 10

Skill	Year	Representations and models	
Recall and use multiplication and division facts for the 3-times table	3	Hundred square Number shapes Counters	Bead strings Number lines Everyday objects
Recall and use multiplication and division facts for the 4-times table	3	Hundred square Number shapes Counters	Bead strings Number lines Everyday objects
Recall and use multiplication and division facts for the 8-times table	3	Hundred square Number shapes	Bead strings Number tracks Everyday objects
Recall and use multiplication and division facts for the 6-times table	4	Hundred square Number shapes	Bead strings Number tracks Everyday objects

Skill	Year	Representations and models	
Recall and use multiplication and division facts for the 7-times table	4	Hundred square Number shapes	Bead strings Number lines
Recall and use multiplication and division facts for the 9-times table	4	Hundred square Number shapes	Bead strings Number lines
Recall and use multiplication and division facts for the 11-times table	4	Hundred square Base 10	Place value counters Number lines
Recall and use multiplication and division facts for the 12-times table	4	Hundred square Base 10	Place value counters Number lines

Skill: 2 times table

Year: 2

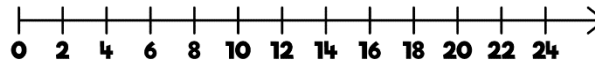
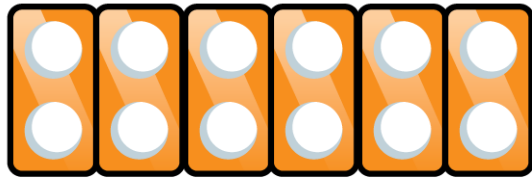

1	2	3	4	5	6	7	8	9	10
11	12	13	14	15	16	17	18	19	20
21	22	23	24	25	26	27	28	29	30
31	32	33	34	35	36	37	38	39	40
41	42	43	44	45	46	47	48	49	50

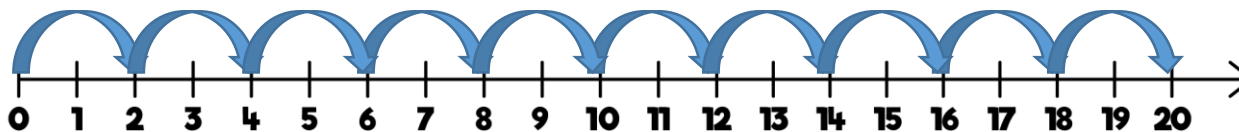
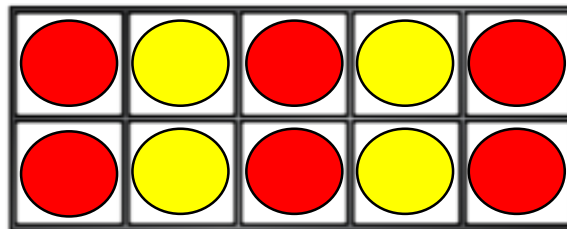

Encourage daily counting in multiples both forwards and backwards. This can be supported using a number line or a hundred square.

Look for patterns in the two times table, using concrete manipulatives to support. Notice how all the numbers are even and there is a pattern in the ones.

Use different models to develop fluency.

Skill: 5 times table

Year: 2

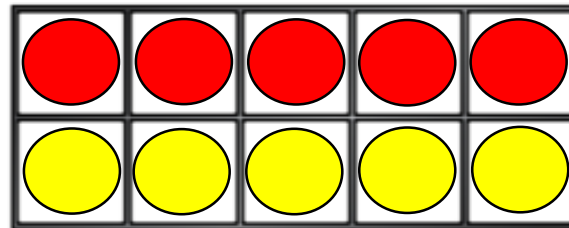
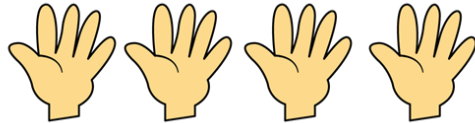
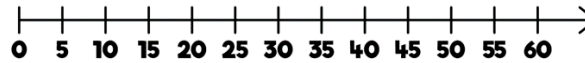
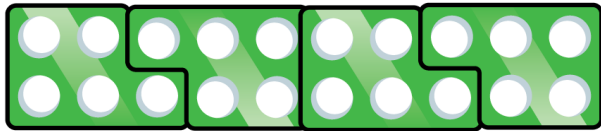

1	2	3	4	5	6	7	8	9	10
11	12	13	14	15	16	17	18	19	20
21	22	23	24	25	26	27	28	29	30
31	32	33	34	35	36	37	38	39	40
41	42	43	44	45	46	47	48	49	50

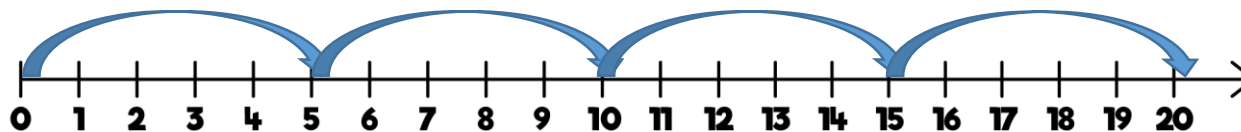
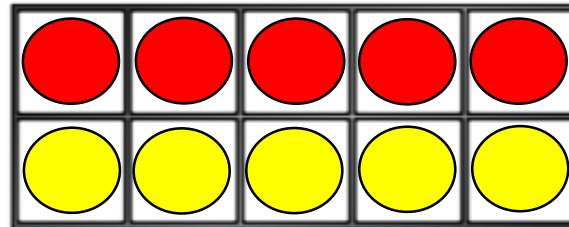

Encourage daily counting in multiples both forwards and backwards. This can be supported using a number line or a hundred square.

Look for patterns in the five times table, using concrete manipulatives to support. Notice the pattern in the ones as well as highlighting the odd, even, odd, even pattern.

Skill: 10 times table

Year: 2

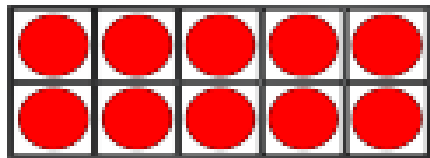
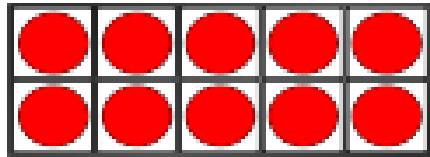
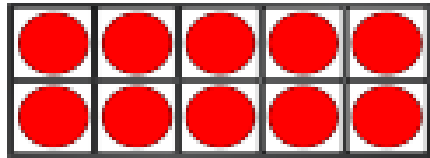
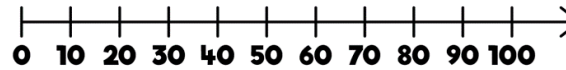
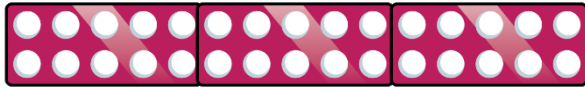

1	2	3	4	5	6	7	8	9	10
11	12	13	14	15	16	17	18	19	20
21	22	23	24	25	26	27	28	29	30
31	32	33	34	35	36	37	38	39	40
41	42	43	44	45	46	47	48	49	50
51	52	53	54	55	56	57	58	59	60
61	62	63	64	65	66	67	68	69	70
71	72	73	74	75	76	77	78	79	80
81	82	83	84	85	86	87	88	89	90
91	92	93	94	95	96	97	98	99	100

Encourage daily counting in multiples both forwards and backwards. This can be supported using a number line or a hundred square.

Look for patterns in the ten times table, using concrete manipulatives to support. Notice the pattern in the digits—the ones are always 0, and the tens increase by 1 ten each time.

Skill: 3 times table

Year: 3

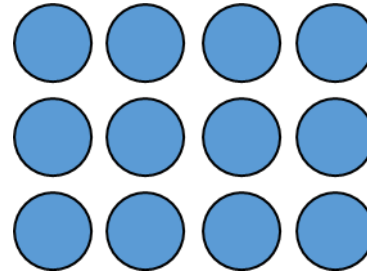
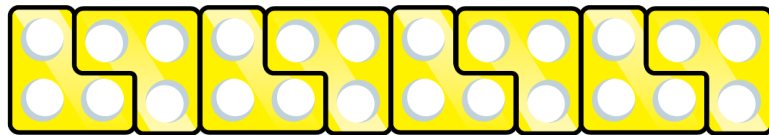

1	2	3	4	5	6	7	8	9	10
11	12	13	14	15	16	17	18	19	20
21	22	23	24	25	26	27	28	29	30
31	32	33	34	35	36	37	38	39	40
41	42	43	44	45	46	47	48	49	50

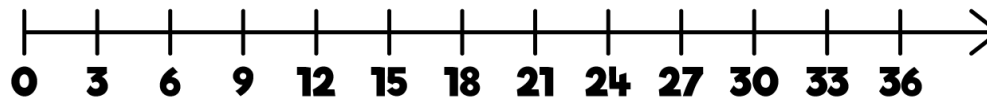
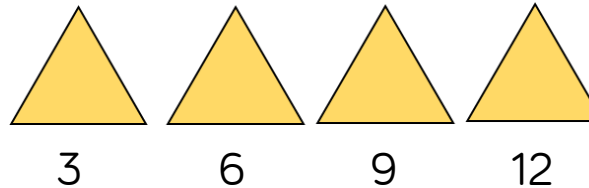

Encourage daily counting in multiples both forwards and backwards. This can be supported using a number line or a hundred square.

Look for patterns in the three times table, using concrete manipulatives to support. Notice the odd, even, odd, even pattern using number shapes to support. Highlight the pattern in the ones using a hundred square.

Skill: 4 times table

Year: 3

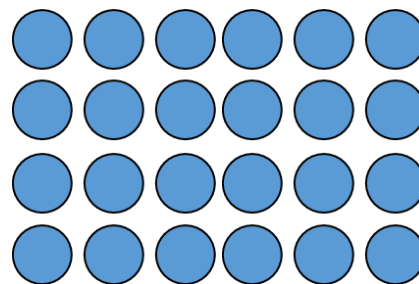

1	2	3	4	5	6	7	8	9	10
11	12	13	14	15	16	17	18	19	20
21	22	23	24	25	26	27	28	29	30
31	32	33	34	35	36	37	38	39	40
41	42	43	44	45	46	47	48	49	50

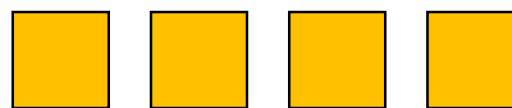

4 8 12 16

4	8	12	16	20
24	28	32	36	40
44	48	52	56	60

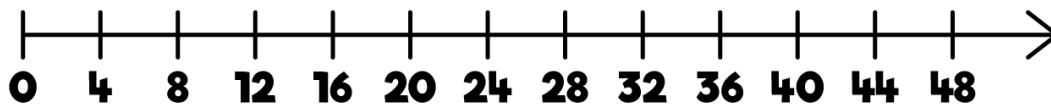

Encourage daily counting in multiples, supported by a number line or a hundred square. Look for patterns in the four times table, using manipulatives to support. Make links to the 2 times table, seeing how each multiple is double the twos. Notice the pattern in the ones within each group of five multiples. Highlight that all the multiples are even using number shapes to support.

Skill: 8 times table

Year: 3

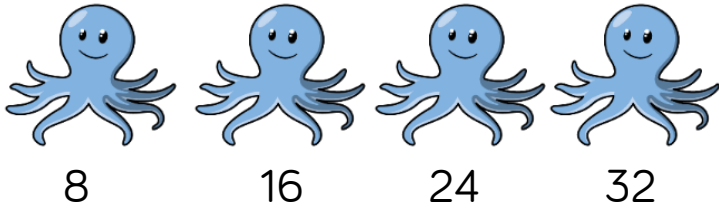
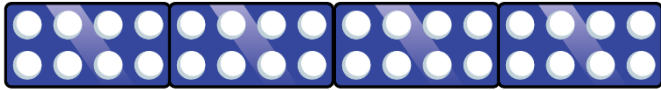

8	16	24	32	40
48	56	64	72	80

1	2	3	4	5	6	7	8	9	10
11	12	13	14	15	16	17	18	19	20
21	22	23	24	25	26	27	28	29	30
31	32	33	34	35	36	37	38	39	40
41	42	43	44	45	46	47	48	49	50
51	52	53	54	55	56	57	58	59	60
61	62	63	64	65	66	67	68	69	70
71	72	73	74	75	76	77	78	79	80
81	82	83	84	85	86	87	88	89	90
91	92	93	94	95	96	97	98	99	100

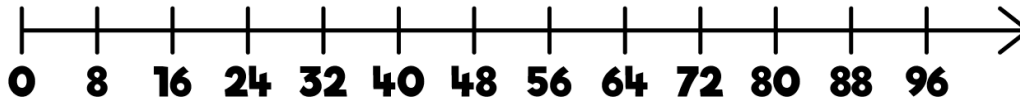

Encourage daily counting in multiples, supported by a number line or a hundred square. Look for patterns in the eight times table, using manipulatives to support. Make links to the 4 times table, seeing how each multiple is double the fours. Notice the pattern in the ones within each group of five multiples. Highlight that all the multiples are even using number shapes to support.

Skill: 6 times table

Year: 4

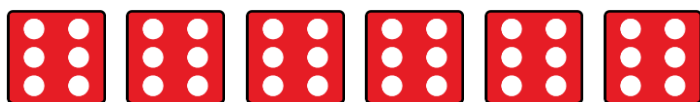

6	12	18	24	30
36	42	48	54	60
66	72	78	84	90

1	2	3	4	5	6	7	8	9	10
11	12	13	14	15	16	17	18	19	20
21	22	23	24	25	26	27	28	29	30
31	32	33	34	35	36	37	38	39	40
41	42	43	44	45	46	47	48	49	50
51	52	53	54	55	56	57	58	59	60
61	62	63	64	65	66	67	68	69	70
71	72	73	74	75	76	77	78	79	80
81	82	83	84	85	86	87	88	89	90
91	92	93	94	95	96	97	98	99	100

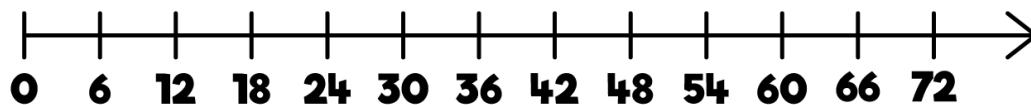

Encourage daily counting in multiples, supported by a number line or a hundred square. Look for patterns in the six times table, using manipulatives to support. Make links to the 3 times table, seeing how each multiple is double the threes. Notice the pattern in the ones within each group of five multiples. Highlight that all the multiples are even using number shapes to support.

Skill: 9 times table

Year: 4



9	18	27	36	45
54	63	72	81	90

1	2	3	4	5	6	7	8	9	10
11	12	13	14	15	16	17	18	19	20
21	22	23	24	25	26	27	28	29	30
31	32	33	34	35	36	37	38	39	40
41	42	43	44	45	46	47	48	49	50
51	52	53	54	55	56	57	58	59	60
61	62	63	64	65	66	67	68	69	70
71	72	73	74	75	76	77	78	79	80
81	82	83	84	85	86	87	88	89	90
91	92	93	94	95	96	97	98	99	100

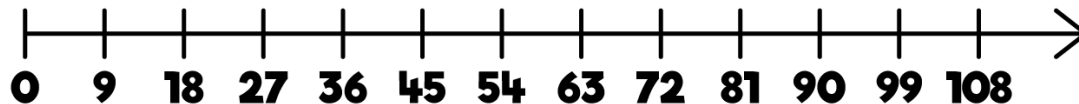

Encourage daily counting in multiples both forwards and backwards. This can be supported using a number line or a hundred square. Look for patterns in the nine times table, using concrete manipulatives to support. Notice the pattern in the tens and ones using the hundred square to support as well as noting the odd, even pattern within the multiples.

Skill: 7 times table

Year: 4



7	14	21	28	35
42	49	56	63	70

1	2	3	4	5	6	7	8	9	10
11	12	13	14	15	16	17	18	19	20
21	22	23	24	25	26	27	28	29	30
31	32	33	34	35	36	37	38	39	40
41	42	43	44	45	46	47	48	49	50
51	52	53	54	55	56	57	58	59	60
61	62	63	64	65	66	67	68	69	70
71	72	73	74	75	76	77	78	79	80
81	82	83	84	85	86	87	88	89	90
91	92	93	94	95	96	97	98	99	100

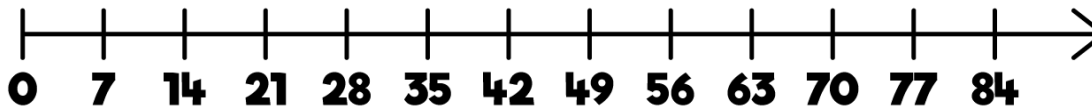

Encourage daily counting in multiples both forwards and backwards, supported by a number line or a hundred square. The seven times table can be trickier to learn due to the lack of obvious pattern in the numbers, however they already know several facts due to commutativity. Children can still see the odd, even pattern in the multiples using number shapes to support.

Skill: 11 times table

Year: 4

11	22	33	44	55	66
77	88	99	110	121	132

1	2	3	4	5	6	7	8	9	10
11	12	13	14	15	16	17	18	19	20
21	22	23	24	25	26	27	28	29	30
31	32	33	34	35	36	37	38	39	40
41	42	43	44	45	46	47	48	49	50
51	52	53	54	55	56	57	58	59	60
61	62	63	64	65	66	67	68	69	70
71	72	73	74	75	76	77	78	79	80
81	82	83	84	85	86	87	88	89	90
91	92	93	94	95	96	97	98	99	100

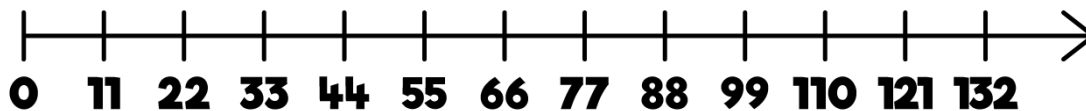
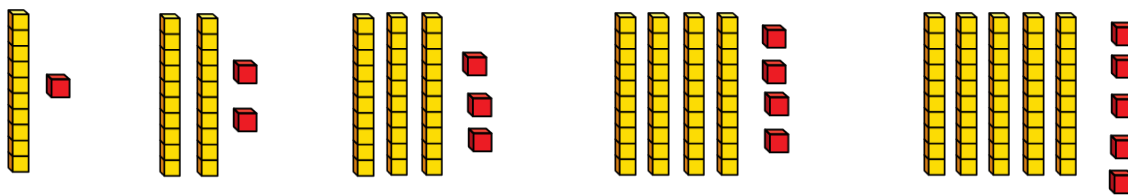
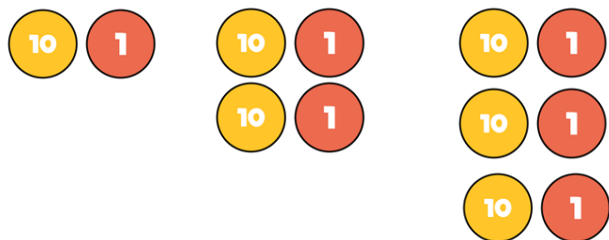

Encourage daily counting in multiples both forwards and backwards. This can be supported using a number line or a hundred square.

Look for patterns in the eleven times table, using concrete manipulatives to support. Notice the pattern in the tens and ones using the hundred square to support. Also consider the pattern after crossing 100

Skill: 12 times table

Year: 4

12	24	36	48	60
72	84	96	108	120
132	144			

1	2	3	4	5	6	7	8	9	10
11	12	13	14	15	16	17	18	19	20
21	22	23	24	25	26	27	28	29	30
31	32	33	34	35	36	37	38	39	40
41	42	43	44	45	46	47	48	49	50
51	52	53	54	55	56	57	58	59	60
61	62	63	64	65	66	67	68	69	70
71	72	73	74	75	76	77	78	79	80
81	82	83	84	85	86	87	88	89	90
91	92	93	94	95	96	97	98	99	100

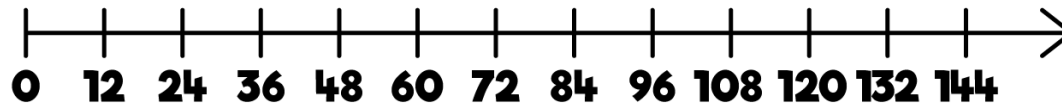
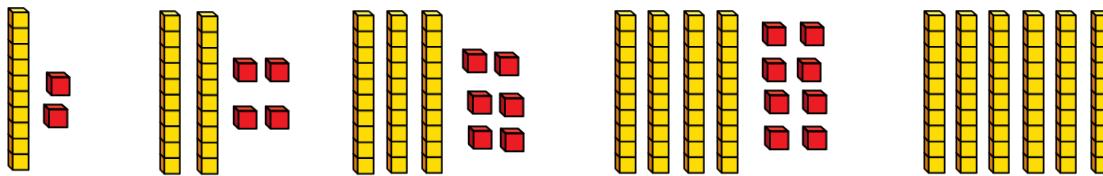
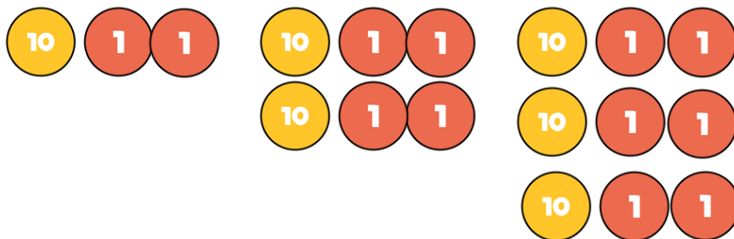

Encourage daily counting in multiples, supported by a number line or a hundred square. Look for patterns in the 12 times table, using manipulatives to support. Make links to the 6 times table, seeing how each multiple is double the sixes. Notice the pattern in the ones within each group of five multiples. The hundred square can support in highlighting this pattern.

Multiplication

Skill	Year	Representations and models	
Solve one-step problems with multiplication	1/2	Bar model Number shapes Counters	Ten frames Bead strings Number lines
Multiply 2-digit by 1-digit numbers	3/4	Place value counters Base 10	Expanded written method Short written method
Multiply 3-digit by 1-digit numbers	4	Place value counters Base 10	Short written method
Multiply 4-digit by 1-digit numbers	5	Place value counters	Short written method

Skill	Year	Representations and models	
Multiply 2-digit by 2-digit numbers	5	Place value counters Base 10	Short written method Grid method
Multiply 2-digit by 3-digit numbers	5	Place value counters	Short written method Grid method
Multiply 2-digit by 4-digit numbers	5/6	Formal written method	

Skill: Solve 1-step problems using multiplication

Year: 1/2

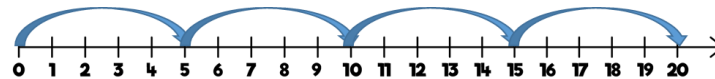
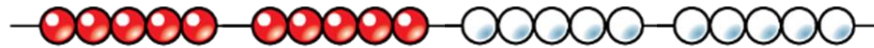
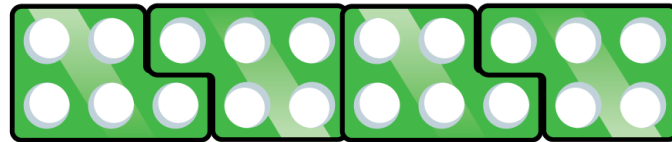
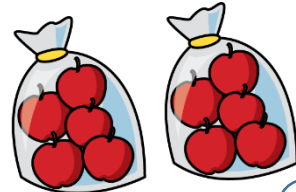
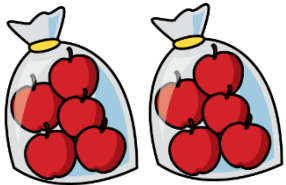

One bag holds 5 apples.
How many apples do 4 bags hold?

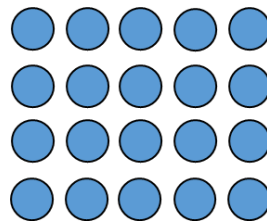
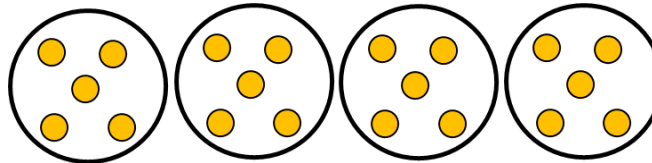
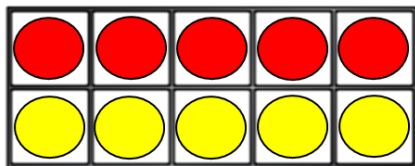
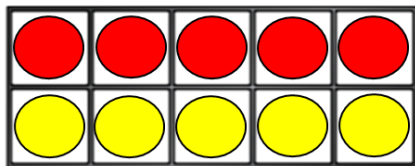

$$5 + 5 + 5 + 5 = 20$$

$$4 \times 5 = 20$$

$$5 \times 4 = 20$$

Children represent multiplication as repeated addition in many different ways.

In Year 1, children use concrete and pictorial representations to solve problems. They are not expected to record multiplication formally.

In Year 2, children are introduced to the multiplication symbol.

Skill: Multiply 2-digit numbers by 1-digit numbers

Year: 3/4

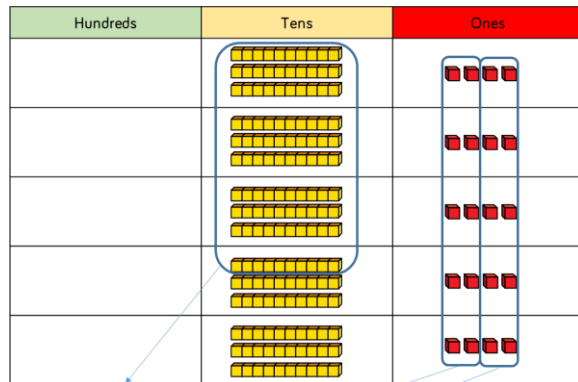

	H	T	O	
		3	4	
x			5	
		2	0	(5 × 4)
+	1	5	0	(5 × 30)
	1	7	0	

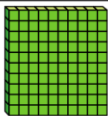

$$34 \times 5 = 170$$

	H	T	O	
		3	4	
x			5	
	1	7	0	
	1	2		

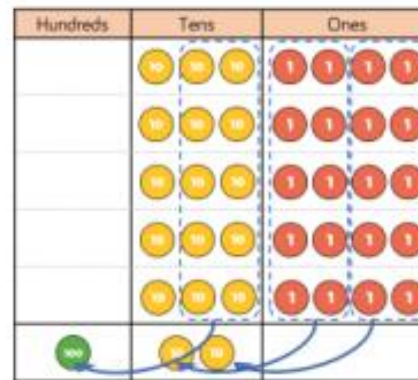

Informal methods and the expanded method are used in Year 3 before moving on to the short multiplication method in Year 4. Place value counters should be used to support the understanding of the method rather than supporting the multiplication, as children should use times table knowledge.

Skill: Multiply 3-digit numbers by 1-digit numbers

Year: 4

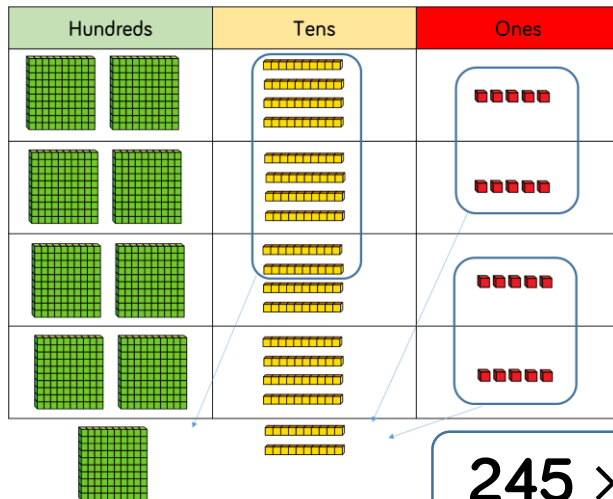

	H	T	O
	2	4	5
x			4
	9	8	0
	1	2	

$$245 \times 4 = 980$$

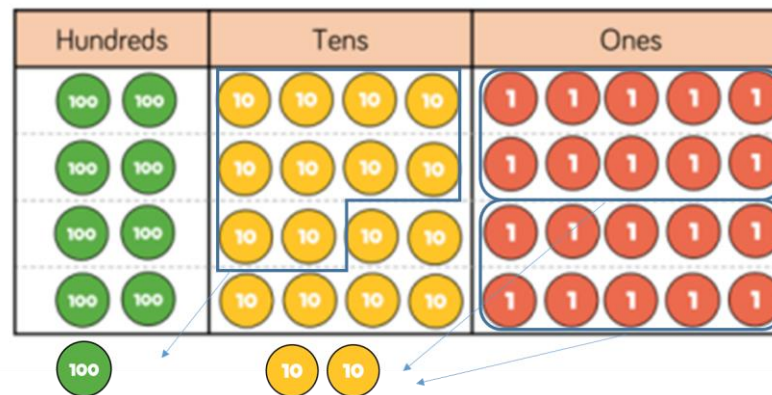

When moving to 3-digit by 1-digit multiplication, encourage children to move towards the short, formal written method.

Base 10 and place value counters continue to support the understanding of the written method. Limit the number of exchanges needed in the questions and move children away from resources when multiplying larger numbers.

Skill: Multiply 4-digit numbers by 1-digit numbers

Year: 5

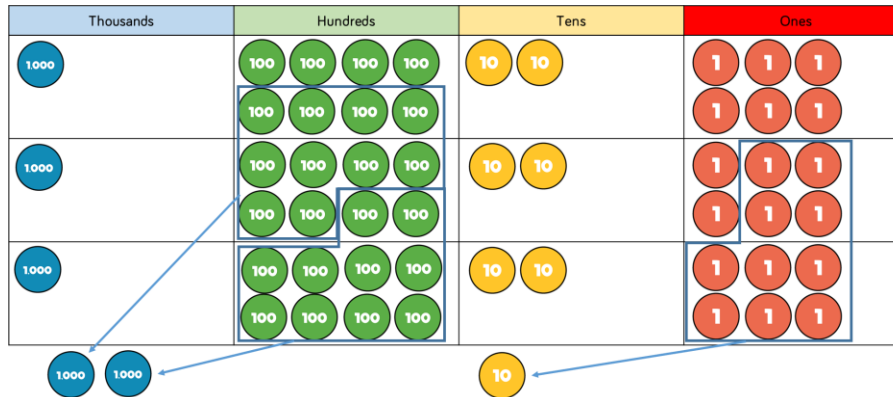

$$1,826 \times 3 = 5,478$$

	Th	H	T	O
	1	8	2	6
×				3
	5	4	7	8
	2		1	

When multiplying 4-digit numbers, place value counters are the best manipulative to use to support children in their understanding of the formal written method. If children are multiplying larger numbers and struggling with their times tables, encourage the use of multiplication grids so children can focus on the use of the written method.

Skill: Multiply 2-digit numbers by 2-digit numbers

Year: 5

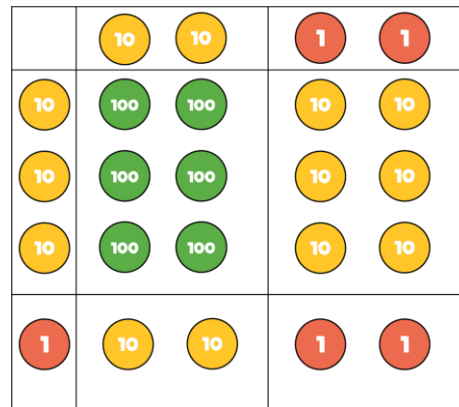
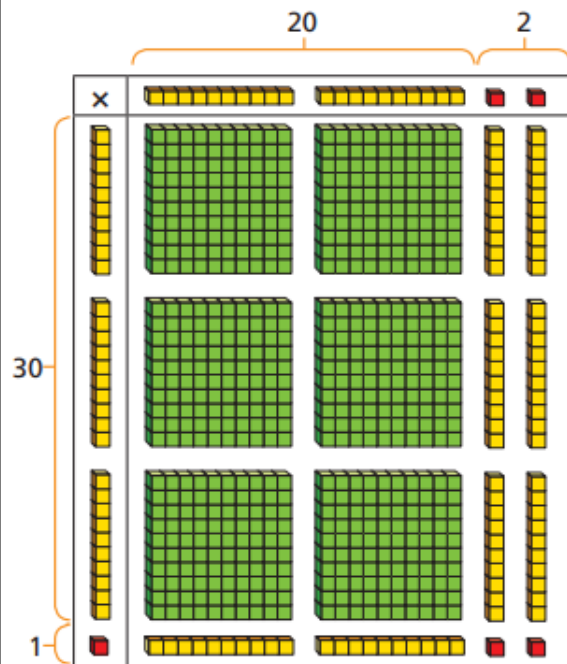

×	20	2
30	600	60
1	20	2

	H	T	O
		2	2
×		3	1
		2	2
	6	6	0
	6	8	2

$$22 \times 31 = 682$$

When multiplying a multi-digit number by 2-digits, use the area model to help children understand the size of the numbers they are using. This links to finding the area of a rectangle by finding the space covered by the Base 10. The grid method matches the area model as an initial written method before moving on to the formal written multiplication method.

Skill: Multiply 3-digit numbers by 2-digit numbers

Year: 5

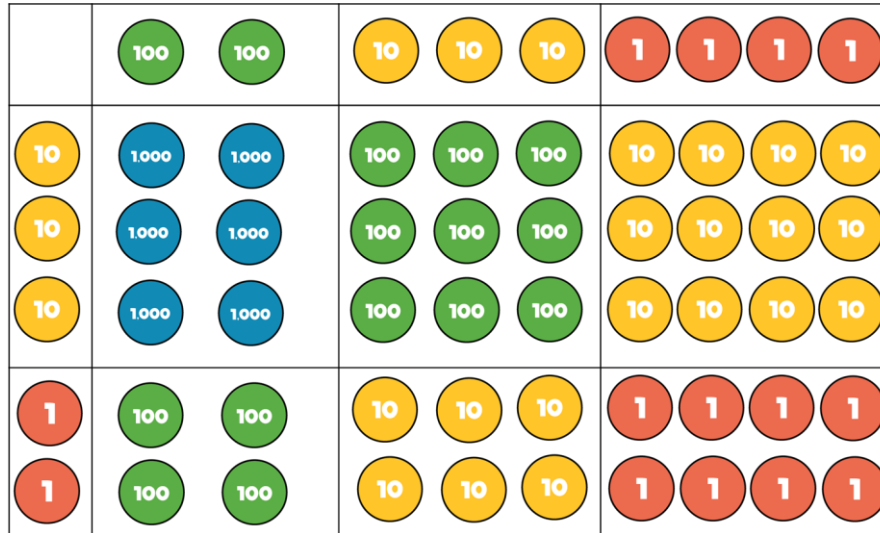

	Th	H	T	O
		2	3	4
x			3	2
		4	6	8
1 7	1 0	2	0	
7	4	8	8	

Children can continue to use the area model when multiplying 3-digits by 2-digits. Place value counters become more efficient to use but Base 10 can be used to highlight the size of numbers.

Children should now move towards the formal written method, seeing the links with the grid method.

$$234 \times 32 = 7,488$$

x	200	30	4
30	6,000	900	120
2	400	60	8

Skill: Multiply 4-digit numbers by 2-digit numbers

Year: 5/6

	TTh	Th	H	T	O
		2	7	3	9
×				2	8
2	1	9	1	2	
<small>2</small>	<small>5</small>	<small>3</small>	<small>7</small>		
5	4	7	8	0	
<small>1</small>		<small>1</small>			
7	6	6	9	2	

1

$$2,739 \times 28 = 76,692$$

When multiplying 4-digits by 2-digits, children should be confident in using the formal written method.

If they are still struggling with times tables, provide multiplication grids to support when they are focusing on the use of the method.

Consider where exchanged digits are placed and make sure this is consistent.

Division

Skill	Year	Representations and models	
Solve one-step problems with division (sharing)	1/2	Bar model Real life objects	Arrays Counters
Solve one-step problems with division (grouping)	1/2	Real life objects Number shapes Bead strings Ten frames	Number lines Arrays Counters
Divide 2-digits by 1-digit (no exchange sharing)	3	Straws Base 10 Bar model	Place value counters Part-whole model
Divide 2-digits by 1-digit (sharing with exchange)	3	Straws Base 10 Bar model	Place value counters Part-whole model

Skill	Year	Representations and models	
Divide 2-digits by 1-digit (sharing with remainders)	3/4	Straws Base 10 Bar model	Place value counters Part-whole model
Divide 2-digits by 1-digit (grouping)	4/5	Place value counters Counters	Place value grid Written short division
Divide 3-digits by 1-digit (sharing with exchange)	4	Base 10 Bar model	Place value counters Part-whole model
Divide 3-digits by 1-digit (grouping)	4/5	Place value counters Counters	Place value grid Written short division

Skill	Year	Representations and models	
Divide 4-digits by 1-digit (grouping)	5	Place value counters Counters	Place value grid Written short division
Divide multi-digits by 2-digits (short division)	6	Written short division	List of multiples
Divide multi-digits by 2-digits (long division)	6	Written long division	List of multiples

Skill: Solve 1-step problems using multiplication (sharing)

Year: 1/2

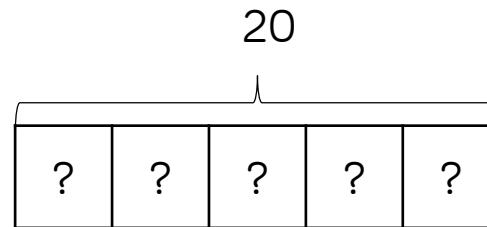
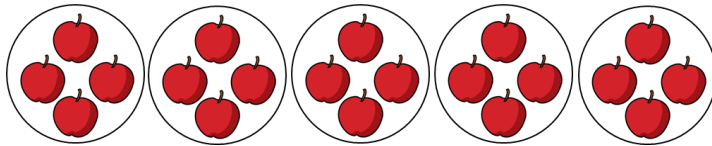

There are 20 apples altogether.
They are shared equally between 5 bags.
How many apples are in each bag?

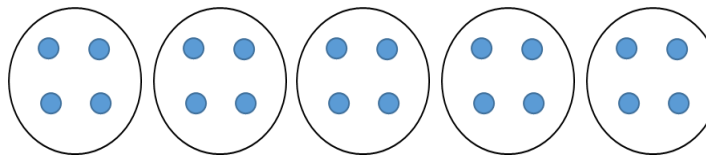
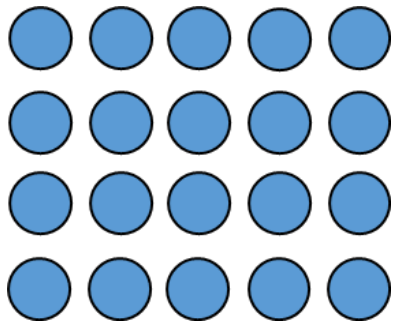

$$20 \div 5 = 4$$

Children solve problems by sharing amounts into equal groups.

In Year 1, children use concrete and pictorial representations to solve problems. They are not expected to record division formally.

In Year 2, children are introduced to the division symbol.

Skill: Solve 1-step problems using division (grouping)

Year: 1/2

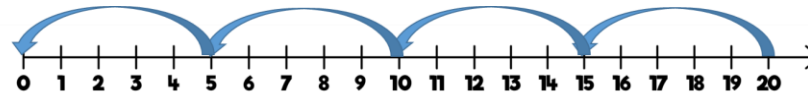
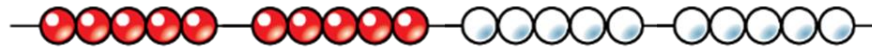
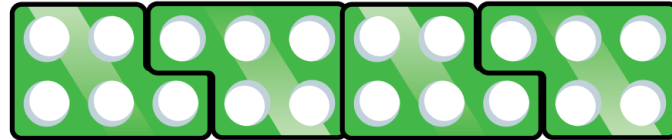
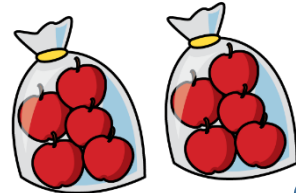
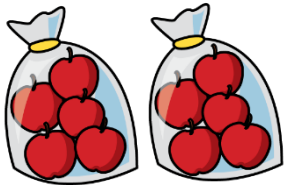

There are 20 apples altogether.
They are put in bags of 5.
How many bags are there?

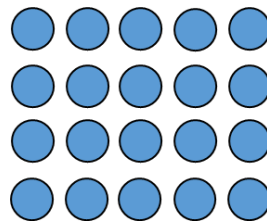
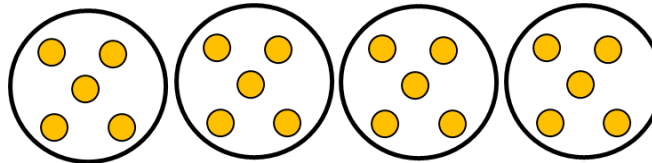
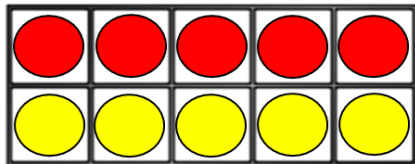
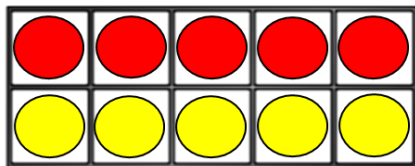

$$20 \div 5 = 4$$

Children solve problems by grouping and counting the number of groups. Grouping encourages children to count in multiples and links to repeated subtraction on a number line. They can use concrete representations in fixed groups such as number shapes which helps to show the link between multiplication and division.

Skill: Divide 2-digits by 1-digit (sharing with no exchange)

Year: 3

Tens	Ones
10 10	1 1 1 1
10 10	1 1 1 1

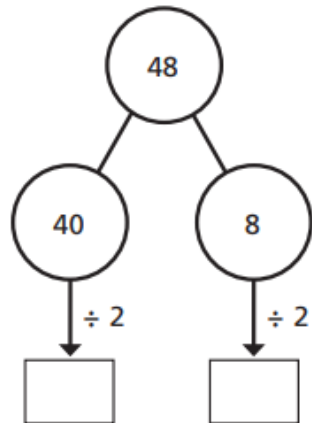
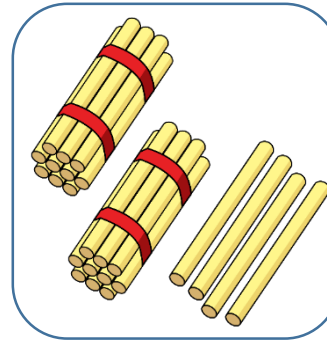
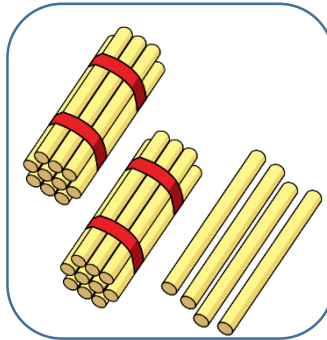

$$48 \div 2 = 24$$

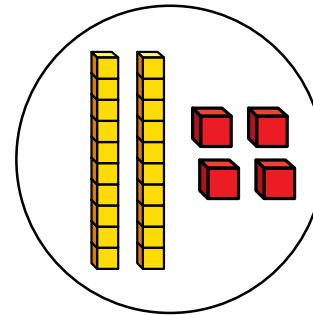
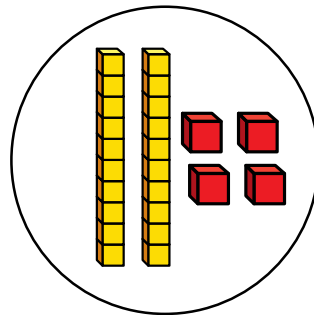

When dividing larger numbers, children can use manipulatives that allow them to partition into tens and ones.







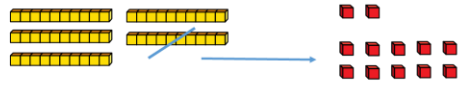

Straws, Base 10 and place value counters can all be used to share numbers into equal groups.

Part-whole models can provide children with a clear written method that matches the concrete representation.

Skill: Divide 2-digits by 1-digit (sharing with exchange)

Year: 3/4







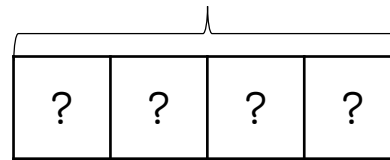

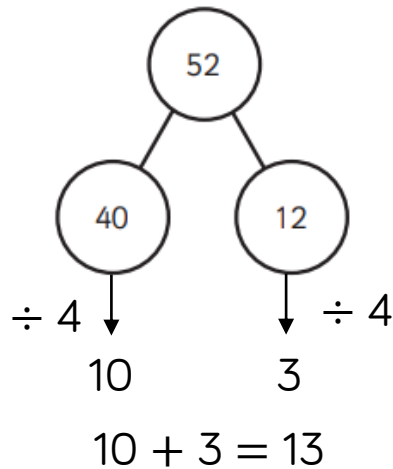

Tens	Ones
	
	
	
	

52



$$52 \div 4 = 13$$



Tens	Ones
	
	
	
	

When dividing numbers involving an exchange, children can use Base 10 and place value counters to exchange one ten for ten ones.







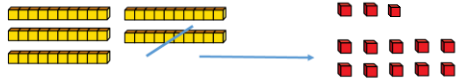

Children should start with the equipment outside the place value grid before sharing the tens and ones equally between the rows.

Flexible partitioning in a part-whole model supports this method.

Skill: Divide 2-digits by 1-digit (sharing with remainders)

Year: 3/4





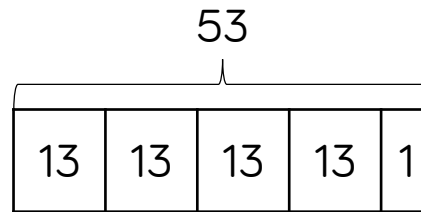



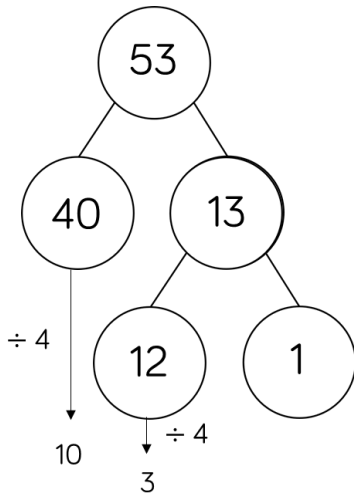

Tens	Ones
	
	
	
	



$$53 \div 4 = 13 \text{ r}1$$



Tens	Ones
	
	
	
	

When dividing numbers with remainders, children can use Base 10 and place value counters to exchange one ten for ten ones. Starting with the equipment outside the place value grid will highlight remainders, as they will be left outside the grid once the equal groups have been made. Flexible partitioning in a part-whole model supports this method.

Skill: Divide 2-digits by 1-digit (grouping)

Year: 5

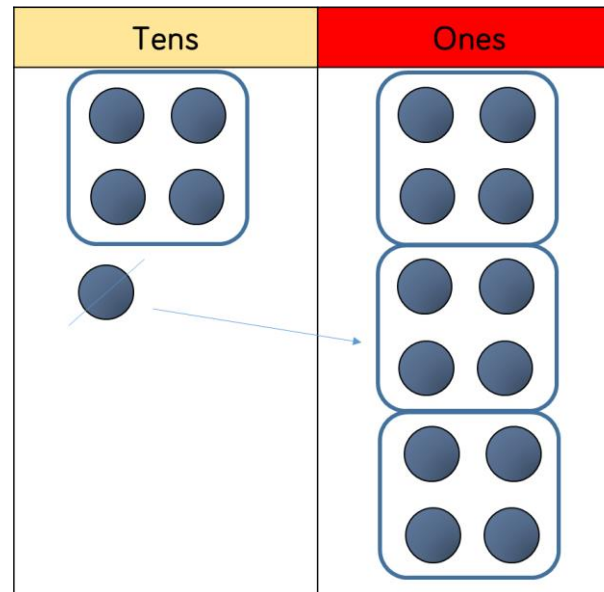
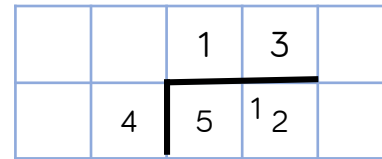
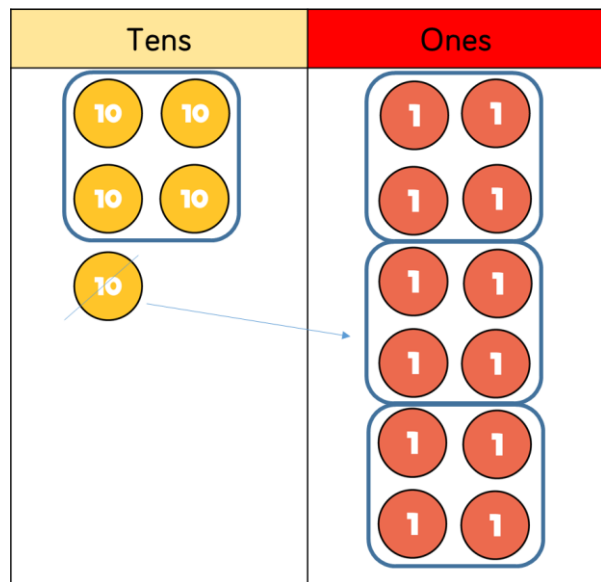

$$52 \div 4 = 13$$

When using the short division method, children use grouping. Starting with the largest place value, they group by the divisor.

Language is important here. Children should consider 'How many groups of 4 tens can we make?' and 'How many groups of 4 ones can we make?'

Remainders can also be seen as they are left ungrouped.

Skill: Divide 3-digits by 1-digit (sharing)

Year: 4

$$844 \div 4 = 211$$

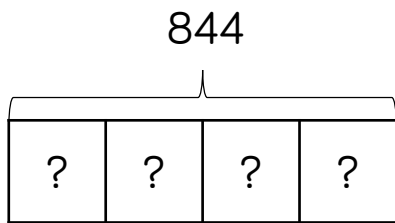

H	T	O
100 100	10	1
100 100	10	1
100 100	10	1
100 100	10	1

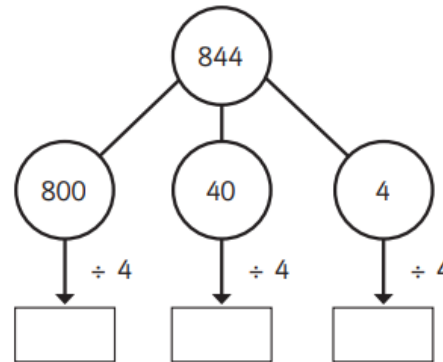

$$856 \div 4 = 214$$

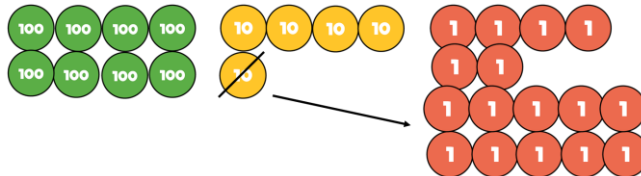
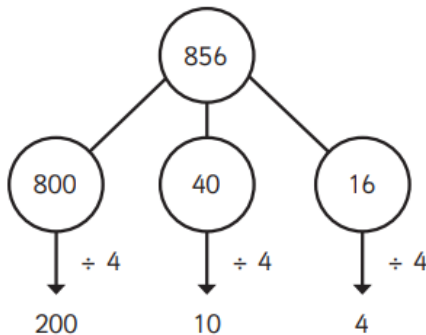

Hundreds	Tens	Ones
100 100	10	1 1 1 1
100 100	10	1 1 1 1
100 100	10	1 1 1 1
100 100	10	1 1 1 1

Children can continue to use place value counters to share 3-digit numbers into equal groups. Children should start with the equipment outside the place value grid before sharing the hundreds, tens and ones equally between the rows. This method can also help to highlight remainders. Flexible partitioning in a part-whole model supports this method.

Skill: Divide 3-digits by 1-digit (grouping)

Year: 5

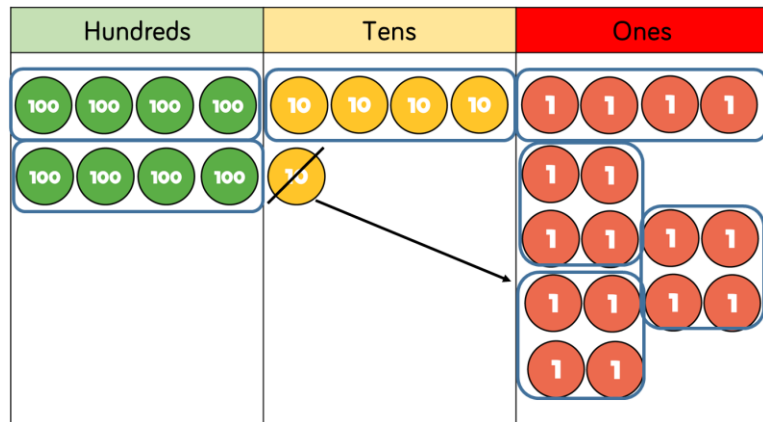

		2	1	4
	4	8	5	16

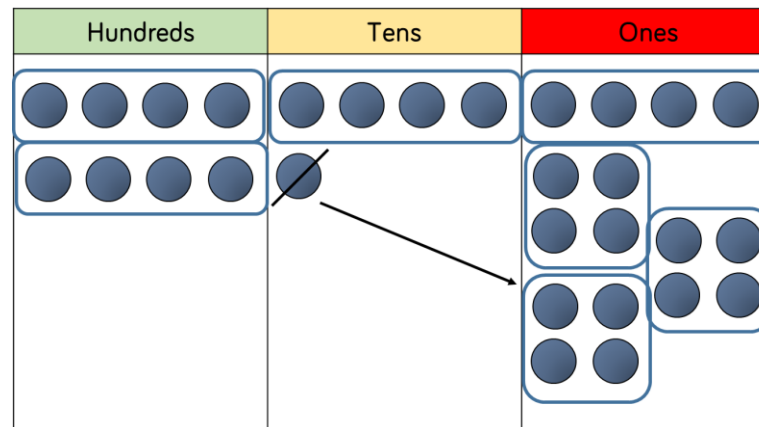

$$856 \div 4 = 214$$

Children can continue to use grouping to support their understanding of short division when dividing a 3-digit number by a 1-digit number.

Place value counters or plain counters can be used on a place value grid to support this understanding. Children can also draw their own counters and group them through a more pictorial method.

Skill: Divide 4-digits by 1-digit (grouping)

Year: 5

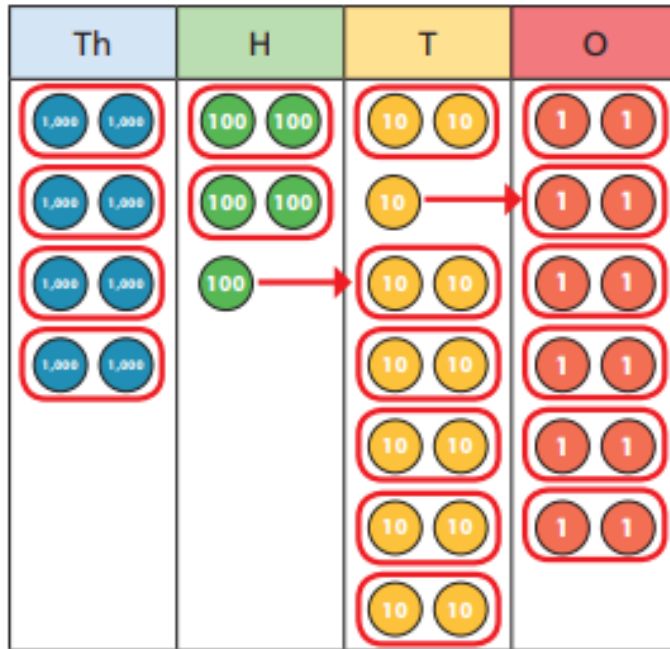

	4	2	6	6
2	8	5	¹ 3	¹ 2

$$8,532 \div 2 = 4,266$$

Place value counters or plain counters can be used on a place value grid to support children to divide 4-digits by 1-digit. Children can also draw their own counters and group them through a more pictorial method.

Children should be encouraged to move away from the concrete and pictorial when dividing numbers with multiple exchanges.

Skill: Divide multi digits by 2-digits (short division)

Year: 6

		0	3	6
	12	4	⁴ 3	⁷ 2

$$432 \div 12 = 36$$

$$7,335 \div 15 = 489$$

	0	4	8	9
15	7	⁷ 3	¹³ 3	¹³ 5

15	30	45	60	75	90	105	120	135	150
----	----	----	----	----	----	-----	-----	-----	-----

When children begin to divide up to 4-digits by 2-digits, written methods become the most accurate as concrete and pictorial representations become less effective. Children can write out multiples to support their calculations with larger remainders. Children will also solve problems with remainders where the quotient can be rounded as appropriate.

Skill: Divide multi-digits by 2-digits (long division)

Year: 6

		0	3	6
1	2	4	3	2
	-	3	6	0
			7	2
	-		7	2
				0

(x30)

$$12 \times 1 = 12$$

$$12 \times 2 = 24$$

$$12 \times 3 = 36$$

$$12 \times 4 = 48$$

$$12 \times 5 = 60$$

(x6)

$$12 \times 6 = 72$$

$$12 \times 7 = 84$$

$$12 \times 8 = 96$$

$$12 \times 7 = 108$$

$$12 \times 10 = 120$$

$$432 \div 12 = 36$$

$$7,335 \div 15 = 489$$

		0	4	8	9
15		7	3	3	5
	-	6	0	0	0
		1	3	3	5
	-	1	2	0	0
			1	3	5
	-		1	3	5
					0

(x400)

$$1 \times 15 = 15$$

$$2 \times 15 = 30$$

$$3 \times 15 = 45$$

(x80)

$$4 \times 15 = 60$$

$$5 \times 15 = 75$$

(x9)

$$10 \times 15 = 150$$

Children can also divide by 2-digit numbers using long division.

Children can write out multiples to support their calculations with larger remainders.

Children will also solve problems with remainders where the quotient can be rounded as appropriate.

Skill: Divide multi digits by 2-digits (long division)

Year: 6

$$372 \div 15 = 24 \text{ r}12$$

			2	4	r	1	2
1	5	3	7	2			
	-	3	0	0			
			7	2			
	-		6	0			
			1	2			

- $1 \times 15 = 15$
- $2 \times 15 = 30$
- $3 \times 15 = 45$
- $4 \times 15 = 60$
- $5 \times 15 = 75$
- $10 \times 15 = 150$

When a remainder is left at the end of a calculation, children can either leave it as a remainder or convert it to a fraction. This will depend on the context of the question.

Children can also answer questions where the quotient needs to be rounded according to the context.

			2	4	$\frac{4}{5}$
1	5	3	7	2	
	-	3	0	0	
			7	2	
	-		6	0	
			1	2	

$$372 \div 15 = 24 \frac{4}{5}$$

Glossary

Array – An ordered collection of counters, cubes or other item in rows and columns.

Commutative – Numbers can be multiplied in any order.

Dividend – In division, the number that is divided.

Divisor – In division, the number by which another is divided.

Exchange – Change a number or expression for another of an equal value.

Factor – A number that multiplies with another to make a product.

Multiplicand – In multiplication, a number to be multiplied by another.

Partitioning – Splitting a number into its component parts.

Product – The result of multiplying one number by another.

Quotient – The result of a division

Remainder – The amount left over after a division when the divisor is not a factor of the dividend.

Scaling – Enlarging or reducing a number by a given amount, called the scale factor

Year 1 - 6

Calculation Policy

Addition and Subtraction

[#MathsEveryoneCan](#)



Calculation Policy

Welcome to the White Rose Maths Calculation Policy.

This document is broken down into addition and subtraction, and multiplication and division.

At the start of each policy, there is an overview of the different models and images that can support the teaching of different concepts. These provide explanations of the benefits of using the models and show the links between different operations.

Each operation is then broken down into skills and each skill has a dedicated page showing the different models and images that could be used to effectively teach that concept.

Ten Frames (within 20)

$8 + 7 = 15$

$14 - 6 = 8$

$7 + 6 + 3 = 16$

Benefits

When adding two single digits, children can make each number on separate ten frames before moving part of one number to make 10 on one of the ten frames. This supports children to see how they have partitioned one of the numbers to make 10, and makes links to effective mental methods of addition.

When subtracting a one-digit number from a two-digit number, firstly make the larger number on 2 ten frames. Remove the smaller number, thinking carefully about how you have partitioned the number to make 10, this supports mental methods of subtraction.

When adding three single-digit numbers, children can make each number on 3 separate 10 ten frames before considering which order to add the numbers in. They may be able to find a number bond to 10 which makes the calculation easier. Once again, the ten frames support the link to effective mental methods of addition as well as the importance of commutativity.

Skill: Add 1 and 2-digit numbers to 20

Year: 1/2

$8 + 7 = 15$

$8 + 7 = 15$

$8 + 7 = 15$

When adding one-digit numbers that cross 10, it is important to highlight the importance of ten ones equaling one ten.

Different manipulatives can be used to represent this exchange. Use concrete resources alongside number lines to support children in understanding how to partition their jumps.

There is an overview of skills linked to year groups to support consistency through out school. A glossary of terms is provided at the end of the calculation policy to support understanding of the key language used to teach the four operations.

Part-Whole Model

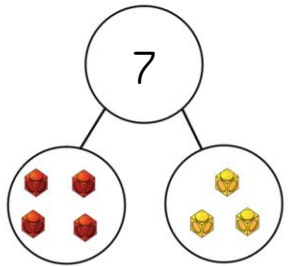

$$7 = 4 + 3$$

$$7 = 3 + 4$$

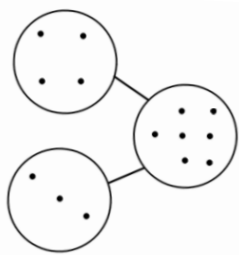

$$7 - 3 = 4$$

$$7 - 4 = 3$$

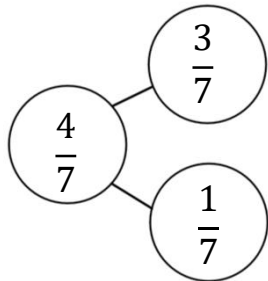
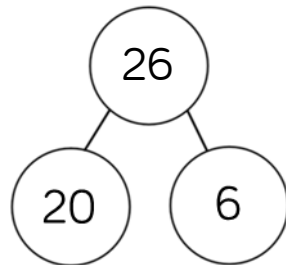
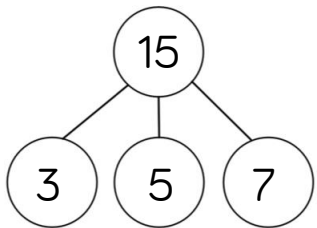
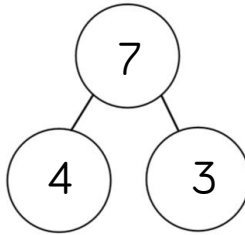

Benefits

This part-whole model supports children in their understanding of aggregation and partitioning. Due to its shape, it can be referred to as a cherry part-whole model.

When the parts are complete and the whole is empty, children use aggregation to add the parts together to find the total.

When the whole is complete and at least one of the parts is empty, children use partitioning (a form of subtraction) to find the missing part.

Part-whole models can be used to partition a number into two or more parts, or to help children to partition a number into tens and ones or other place value columns.

In KS2, children can apply their understanding of the part-whole model to add and subtract fractions, decimals and percentages.

Bar Model (single)

Concrete



Discrete

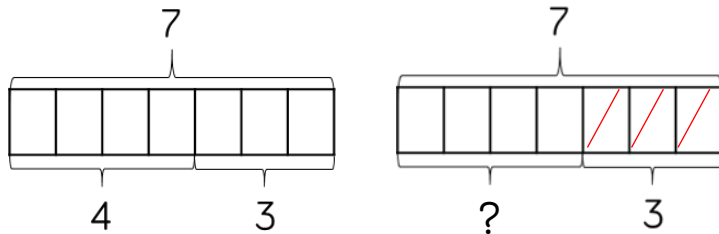

Combination

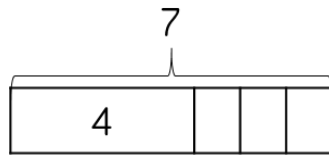

Continuous

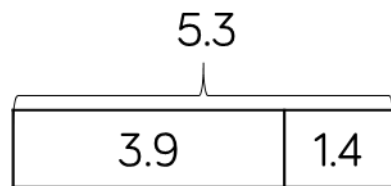
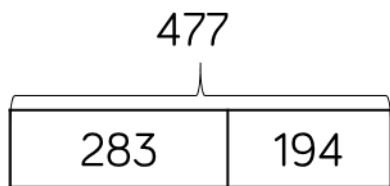
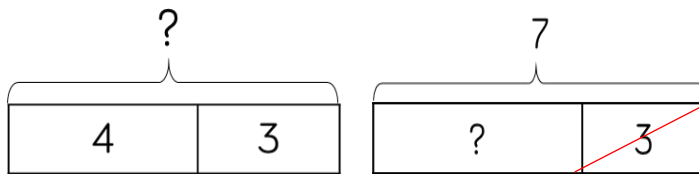

Benefits

The single bar model is another type of a part-whole model that can support children in representing calculations to help them unpick the structure.

Cubes and counters can be used in a line as a concrete representation of the bar model.

Discrete bar models are a good starting point with smaller numbers. Each box represents one whole.

The combination bar model can support children to calculate by counting on from the larger number. It is a good stepping stone towards the continuous bar model.

Continuous bar models are useful for a range of values. Each rectangle represents a number. The question mark indicates the value to be found.

In KS2, children can use bar models to represent larger numbers, decimals and fractions.

Bar Model (multiple)

Discrete

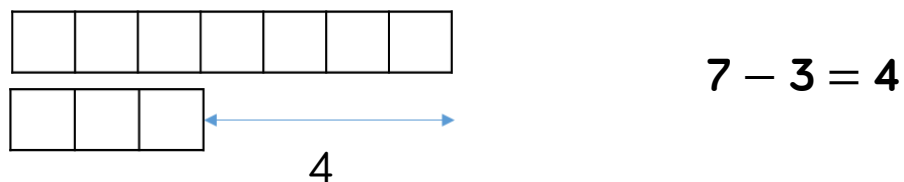
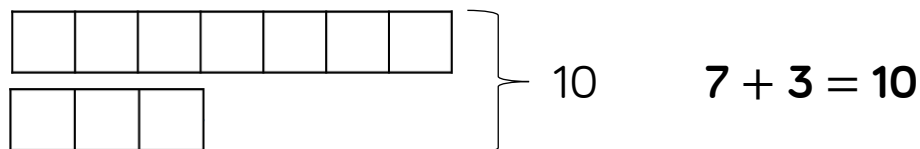

Continuous

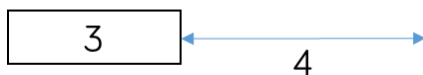
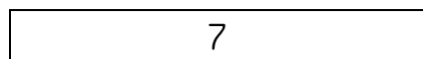

$$7 - 3 = 4$$

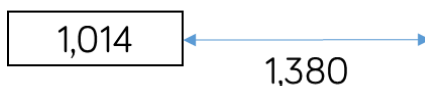
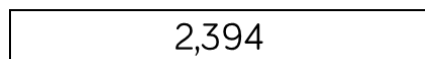

$$2,394 - 1,014 = 1,380$$

Benefits

The multiple bar model is a good way to compare quantities whilst still unpicking the structure.

Two or more bars can be drawn, with a bracket labelling the whole positioned on the right hand side of the bars. Smaller numbers can be represented with a discrete bar model whilst continuous bar models are more effective for larger numbers.

Multiple bar models can also be used to represent the difference in subtraction. An arrow can be used to model the difference.

When working with smaller numbers, children can use cubes and a discrete model to find the difference. This supports children to see how counting on can help when finding the difference.

Number Shapes



$$7 = 4 + 3$$



$$7 = 3 + 4$$

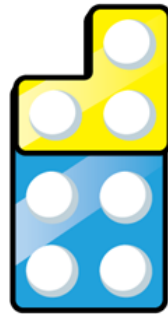

$$7 - 3 = 4$$

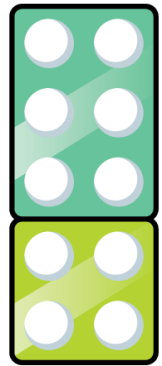

$$6 + 4$$

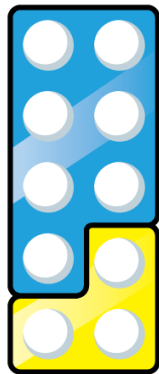

$$7 + 3$$

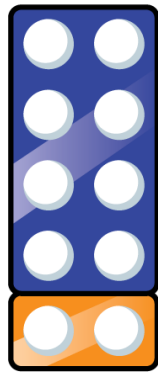

$$8 + 2$$

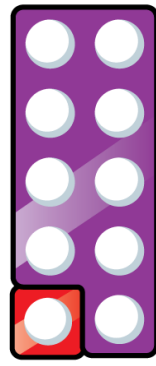

$$9 + 1$$

Benefits

Number shapes can be useful to support children to subitise numbers as well as explore aggregation, partitioning and number bonds.

When adding numbers, children can see how the parts come together making a whole. As children use number shapes more often, they can start to subitise the total due to their familiarity with the shape of each number.

When subtracting numbers, children can start with the whole and then place one of the parts on top of the whole to see what part is missing. Again, children will start to be able to subitise the part that is missing due to their familiarity with the shapes.

Children can also work systematically to find number bonds. As they increase one number by 1, they can see that the other number decreases by 1 to find all the possible number bonds for a number.

Cubes

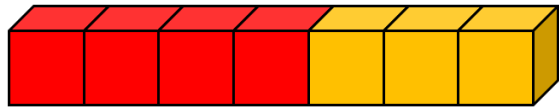

$$7 = 4 + 3$$

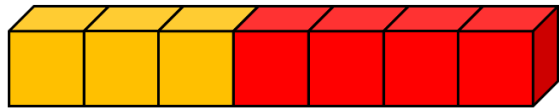

$$7 = 3 + 4$$

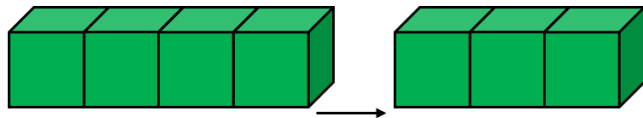

$$7 - 3 = 4$$

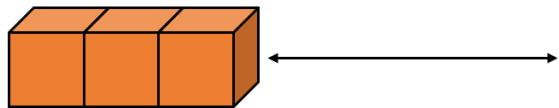
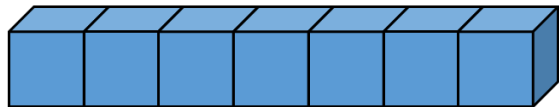

$$7 - 3 = 4$$

Benefits

Cubes can be useful to support children with the addition and subtraction of one-digit numbers.

When adding numbers, children can see how the parts come together to make a whole. Children could use two different colours of cubes to represent the numbers before putting them together to create the whole.

When subtracting numbers, children can start with the whole and then remove the number of cubes that they are subtracting in order to find the answer. This model of subtraction is reduction, or take away.

Cubes can also be useful to look at subtraction as difference. Here, both numbers are made and then lined up to find the difference between the numbers.

Cubes are useful when working with smaller numbers but are less efficient with larger numbers as they are difficult to subitise and children may miscount them.

Ten Frames (within 10)

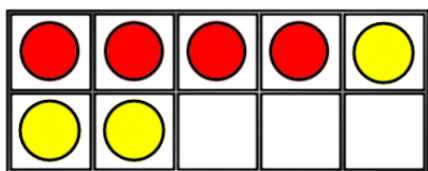

$$4 + 3 = 7$$

$$3 + 4 = 7$$

$$7 - 3 = 4$$

$$7 - 4 = 3$$

4 is a part.

3 is a part.

7 is the whole.

First

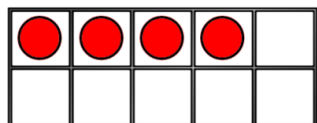

Then

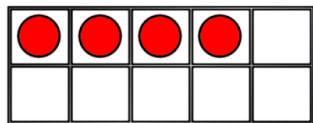

$$4 + 3 = 7$$

Now

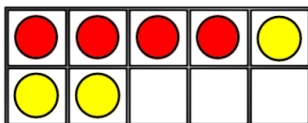

First

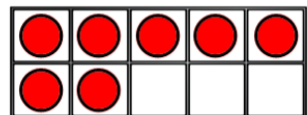

Then

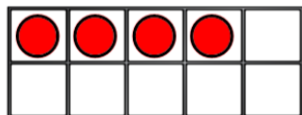

$$7 - 3 = 4$$

Now

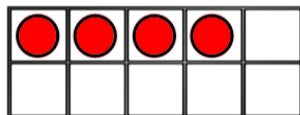

Benefits

When adding and subtracting within 10, the ten frame can support children to understand the different structures of addition and subtraction.

Using the language of parts and wholes represented by objects on the ten frame introduces children to aggregation and partitioning.

Aggregation is a form of addition where parts are combined together to make a whole. Partitioning is a form of subtraction where the whole is split into parts. Using these structures, the ten frame can enable children to find all the number bonds for a number.

Children can also use ten frames to look at augmentation (increasing a number) and take-away (decreasing a number). This can be introduced through a first, then, now structure which shows the change in the number in the 'then' stage. This can be put into a story structure to help children understand the change e.g. First, there were 7 cars. Then, 3 cars left. Now, there are 4 cars.

Ten Frames (within 20)

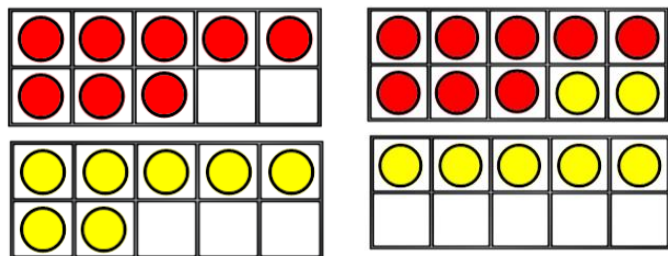

$$8 + 7 = 15$$

Diagram showing the partitioning of 7 into 2 and 5. A blue oval encircles the 8 and the 2, with lines connecting them to the 15 in the equation above.

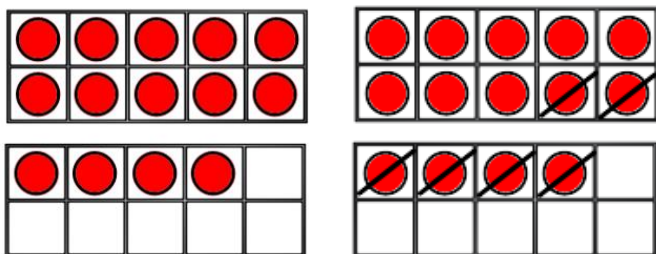

$$14 - 6 = 8$$

Diagram showing the partitioning of 14 into 4 and 10. A blue oval encircles the 14 and the 4, with lines connecting them to the 8 in the equation above.

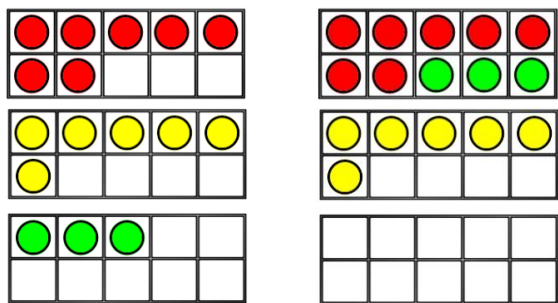

$$7 + 6 + 3 = 16$$

Diagram showing the partitioning of 16 into 10 and 6. Lines connect the 16 to a 10 below and a 6 to the right.

Benefits

When adding two single digits, children can make each number on separate ten frames before moving part of one number to make 10 on one of the ten frames. This supports children to see how they have partitioned one of the numbers to make 10, and makes links to effective mental methods of addition.

When subtracting a one-digit number from a two-digit number, firstly make the larger number on 2 ten frames. Remove the smaller number, thinking carefully about how you have partitioned the number to make 10, this supports mental methods of subtraction.

When adding three single-digit numbers, children can make each number on 3 separate 10 frames before considering which order to add the numbers in. They may be able to find a number bond to 10 which makes the calculation easier. Once again, the ten frames support the link to effective mental methods of addition as well as the importance of commutativity.

Bead Strings

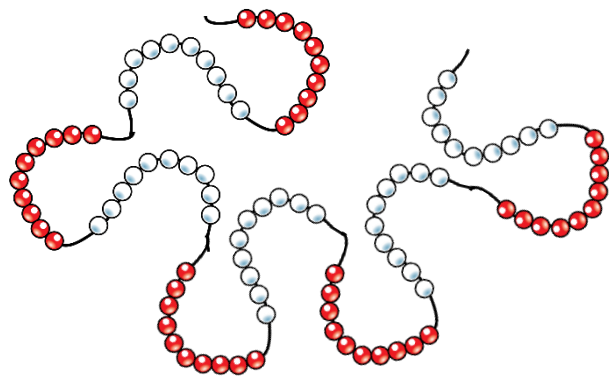
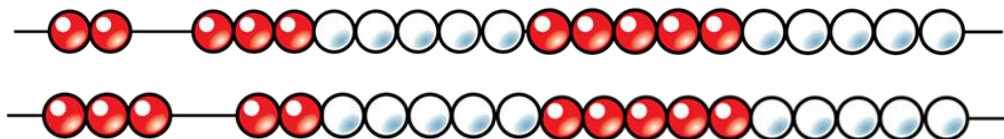
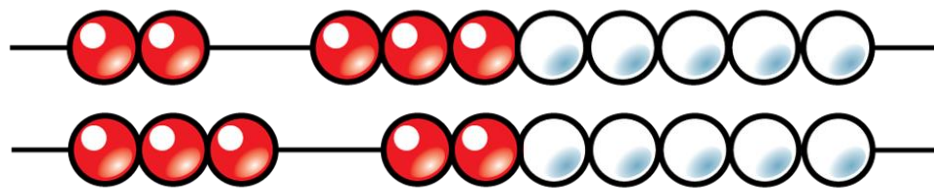

Benefits

Different sizes of bead strings can support children at different stages of addition and subtraction.

Bead strings to 10 are very effective at helping children to investigate number bonds up to 10.

They can help children to systematically find all the number bonds to 10 by moving one bead at a time to see the different numbers they have partitioned the 10 beads into e.g. $2 + 8 = 10$, move one bead, $3 + 7 = 10$.

Bead strings to 20 work in a similar way but they also group the beads in fives. Children can apply their knowledge of number bonds to 10 and see the links to number bonds to 20.

Bead strings to 100 are grouped in tens and can support children in number bonds to 100 as well as helping when adding by making ten. Bead strings can show a link to adding to the next 10 on number lines which supports a mental method of addition.

Number Tracks

$$5 + 3 = 8$$

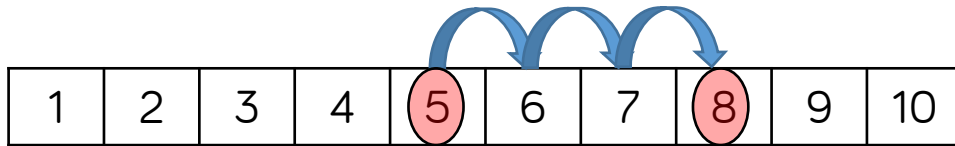

$$10 - 4 = 6$$

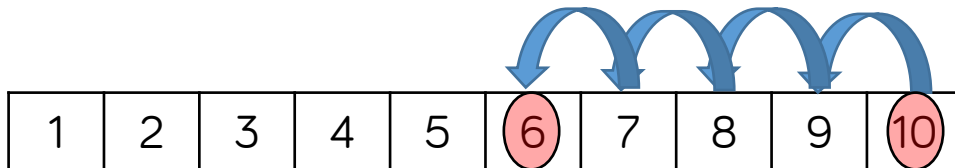

$$8 + 7 = 15$$

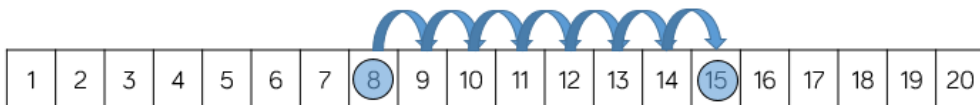

Benefits

Number tracks are useful to support children in their understanding of augmentation and reduction.

When adding, children count on to find the total of the numbers. On a number track, children can place a counter on the starting number and then count on to find the total.

When subtracting, children count back to find their answer. They start at the minuend and then take away the subtrahend to find the difference between the numbers.

Number tracks can work well alongside ten frames and bead strings which can also model counting on or counting back.

Playing board games can help children to become familiar with the idea of counting on using a number track before they move on to number lines.

Number Lines (labelled)

$$5 + 3 = 8$$

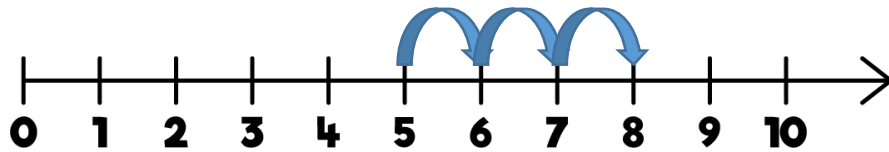

$$8 + 7 = 15$$

8 is circled in blue. A bracket connects 8 to 2, and another bracket connects 7 to 5.

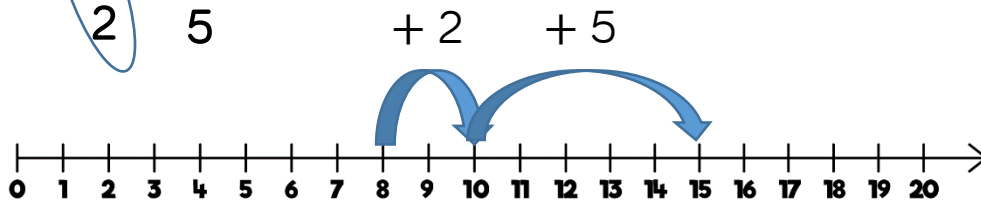

$$14 - 6 = 8$$

14 is circled in blue. A bracket connects 14 to 4, and another bracket connects 6 to 2.

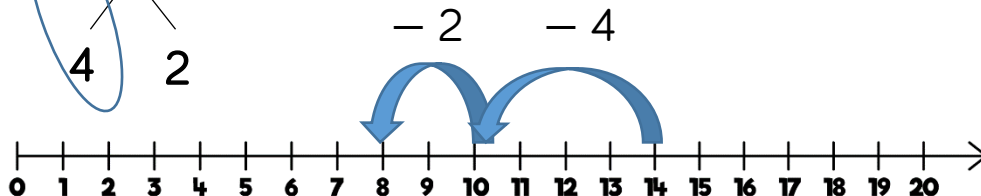

Benefits

Labelled number lines support children in their understanding of addition and subtraction as augmentation and reduction.

Children can start by counting on or back in ones, up or down the number line. This skill links directly to the use of the number track.

Progressing further, children can add numbers by jumping to the nearest 10 and then jumping to the total. This links to the making 10 method which can also be supported by ten frames. The smaller number is partitioned to support children to make a number bond to 10 and to then add on the remaining part.

Children can subtract numbers by firstly jumping to the nearest 10. Again, this can be supported by ten frames so children can see how they partition the smaller number into the two separate jumps.

Number Lines (blank)

$$35 + 37 = 72$$

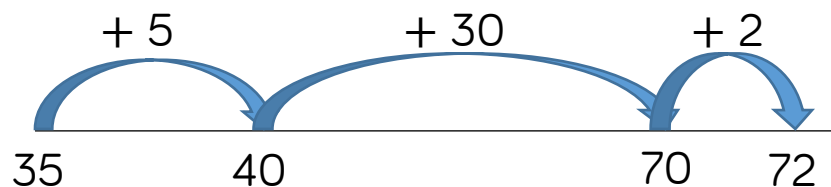

$$35 + 37 = 72$$

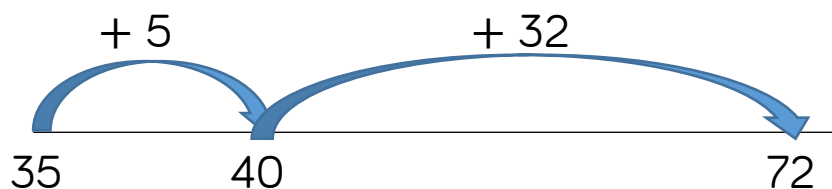

$$72 - 35 = 37$$

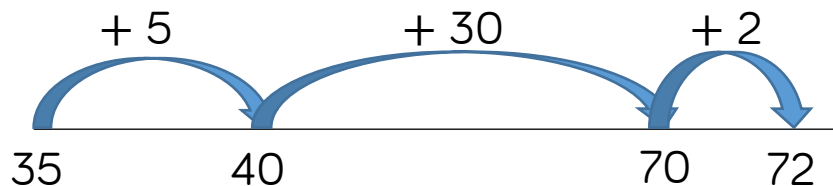

Benefits

Blank number lines provide children with a structure to add and subtract numbers in smaller parts.

Developing from labelled number lines, children can add by jumping to the nearest 10 and then adding the rest of the number either as a whole or by adding the tens and ones separately.

Children may also count back on a number line to subtract, again by jumping to the nearest 10 and then subtracting the rest of the number.

Blank number lines can also be used effectively to help children subtract by finding the difference between numbers. This can be done by starting with the smaller number and then counting on to the larger number. They then add up the parts they have counted on to find the difference between the numbers.

Straws

$$7 + 6 = 13$$

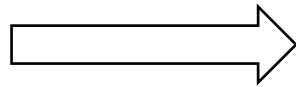
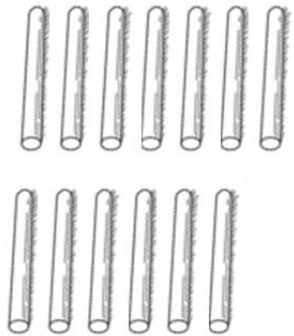

bundle together
groups of 10

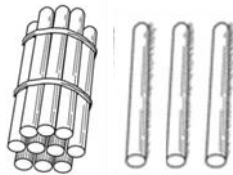

$$42 - 17 = 25$$

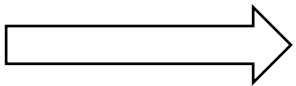
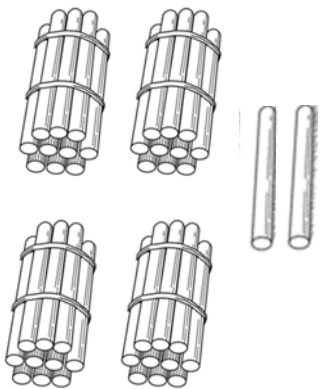

unbundle group
of 10 straws

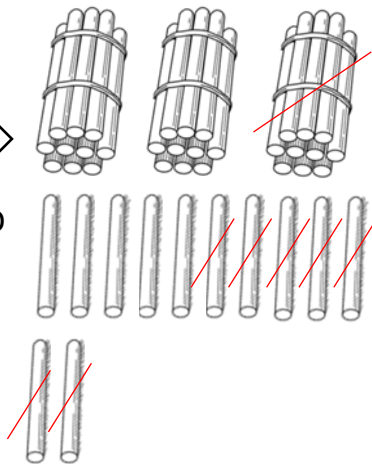

Benefits

Straws are an effective way to support children in their understanding of exchange when adding and subtracting 2-digit numbers.

Children can be introduced to the idea of bundling groups of ten when adding smaller numbers and when representing 2-digit numbers. Use elastic bands or other ties to make bundles of ten straws.

When adding numbers, children bundle a group of 10 straws to represent the exchange from 10 ones to 1 ten. They then add the individual straws (ones) and bundles of straws (tens) to find the total.

When subtracting numbers, children unbundle a group of 10 straws to represent the exchange from 1 ten to 10 ones.

Straws provide a good stepping stone to adding and subtracting with Base 10/Dienes.

Base 10/Dienes (addition)

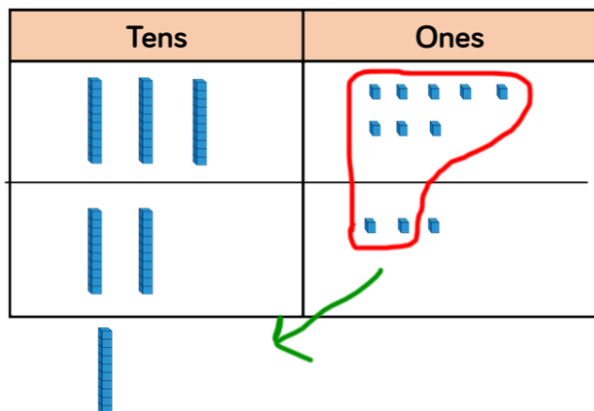

$$\begin{array}{r} 38 \\ + 23 \\ \hline 61 \\ \hline 1 \end{array}$$

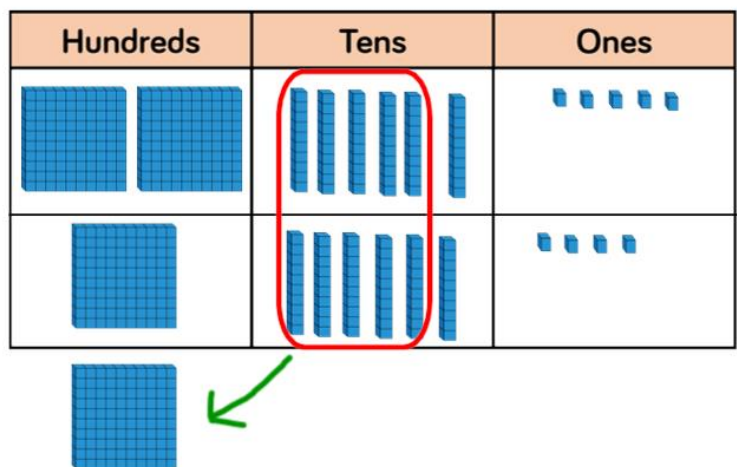

$$\begin{array}{r} 265 \\ + 164 \\ \hline 429 \\ \hline 1 \end{array}$$

Benefits

Using Base 10 or Dienes is an effective way to support children's understanding of column addition. It is important that children write out their calculations alongside using or drawing Base 10 so they can see the clear links between the written method and the model.

Children should first add without an exchange before moving on to addition with exchange. The representation becomes less efficient with larger numbers due to the size of Base 10. In this case, place value counters may be the better model to use.

When adding, always start with the smallest place value column. Here are some questions to support children.

- How many ones are there altogether?
- Can we make an exchange? (Yes or No)
- How many do we exchange? (10 ones for 1 ten, show exchanged 10 in tens column by writing 1 in column)
- How many ones do we have left? (Write in ones column)

Repeat for each column.

Base 10/Dienes (subtraction)

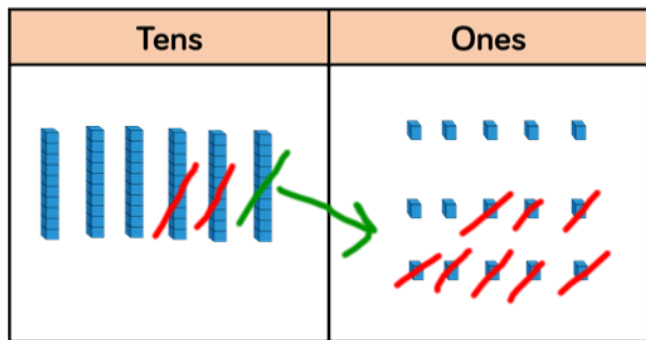

$$\begin{array}{r}
 \overset{5}{\cancel{6}} \overset{1}{\cancel{5}} \\
 - 28 \\
 \hline
 37 \\
 \hline
 \end{array}$$

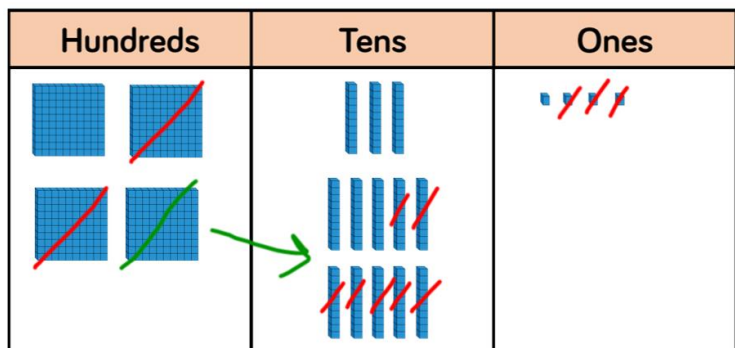

$$\begin{array}{r}
 \overset{3}{\cancel{4}} \overset{1}{\cancel{3}} 5 \\
 - 273 \\
 \hline
 162 \\
 \hline
 \end{array}$$

Benefits

Using Base 10 or Dienes is an effective way to support children's understanding of column subtraction. It is important that children write out their calculations alongside using or drawing Base 10 so they can see the clear links between the written method and the model.

Children should first subtract without an exchange before moving on to subtraction with exchange. When building the model, children should just make the minuend using Base 10, they then subtract the subtrahend. Highlight this difference to addition to avoid errors by making both numbers. Children start with the smallest place value column. When there are not enough ones/tens/hundreds to subtract in a column, children need to move to the column to the left and exchange e.g. exchange 1 ten for 10 ones. They can then subtract efficiently.

This model is efficient with up to 4-digit numbers. Place value counters are more efficient with larger numbers and decimals.

Place Value Counters (addition)

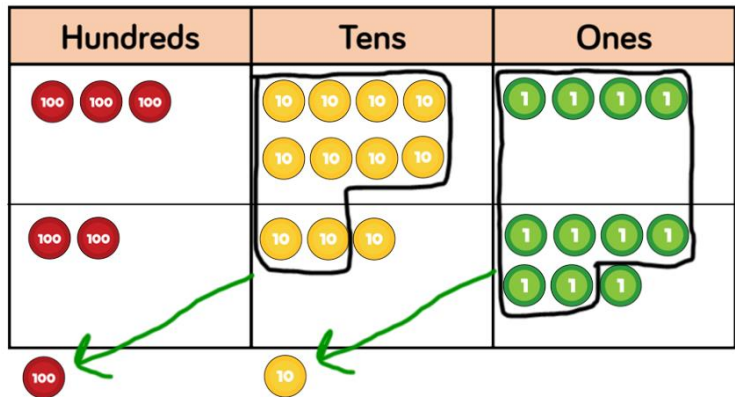

$$\begin{array}{r} 384 \\ + 237 \\ \hline 621 \\ 11 \end{array}$$

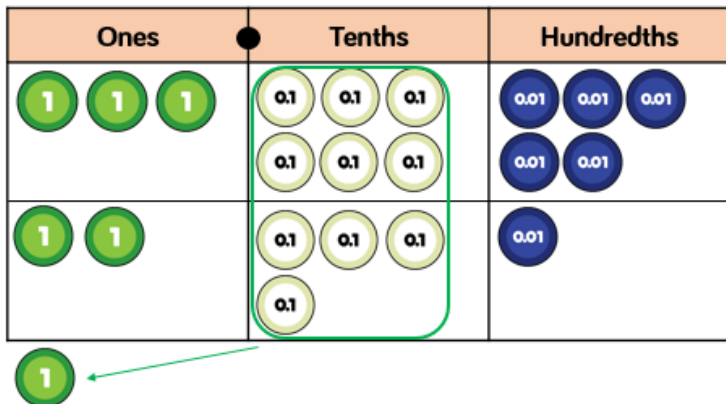

$$\begin{array}{r} 3.65 \\ + 2.41 \\ \hline 6.06 \\ 1 \end{array}$$





Benefits

Using place value counters is an effective way to support children's understanding of column addition. It is important that children write out their calculations alongside using or drawing counters so they can see the clear links between the written method and the model.



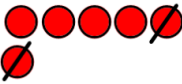
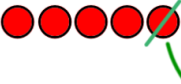





Children should first add without an exchange before moving on to addition with exchange. Different place value counters can be used to represent larger numbers or decimals. If you don't have place value counters, use normal counters on a place value grid to enable children to experience the exchange between columns.

When adding money, children can also use coins to support their understanding. It is important that children consider how the coins link to the written calculation especially when adding decimal amounts.

Place Value Counters (Subtraction)

Hundreds	Tens	Ones
		
		

$$\begin{array}{r}
 \overset{4}{\cancel{6}}\overset{1}{\cancel{5}}2 \\
 - 207 \\
 \hline
 445 \\
 \hline
 \end{array}$$

Thousands	Hundreds	Tens	Ones
			
			

$$\begin{array}{r}
 \overset{3}{\cancel{4}}\overset{1}{\cancel{3}}57 \\
 - 2735 \\
 \hline
 1622 \\
 \hline
 \end{array}$$

Benefits

Using place value counters is an effective way to support children's understanding of column subtraction. It is important that children write out their calculations alongside using or drawing counters so they can see the clear links between the written method and the model.

Children should first subtract without an exchange before moving on to subtraction with exchange. If you don't have place value counters, use normal counters on a place value grid to enable children to experience the exchange between columns.

When building the model, children should just make the minuend using counters, they then subtract the subtrahend. Children start with the smallest place value column. When there are not enough ones/tens/hundreds to subtract in a column, children need to move to the column to the left and exchange e.g. exchange 1 ten for 10 ones. They can then subtract efficiently.

Addition

Skill	Year	Representations and models	
Add two 1-digit numbers to 10	1	Part-whole model Bar model Number shapes	Ten frames (within 10) Bead strings (10) Number tracks
Add 1 and 2-digit numbers to 20	1	Part-whole model Bar model Number shapes Ten frames (within 20)	Bead strings (20) Number tracks Number lines (labelled) Straws
Add three 1-digit numbers	2	Part-whole model Bar model	Ten frames (within 20) Number shapes
Add 1 and 2-digit numbers to 100	2	Part-whole model Bar model Number lines (labelled)	Number lines (blank) Straws Hundred square

Skill	Year	Representations and models
Add two 2-digit numbers	2	Part-whole model Bar model Number lines (blank) Straws Base 10 Place value counters
Add with up to 3-digits	3	Part-whole model Bar model Base 10 Place value counters Column addition
Add with up to 4-digits	4	Part-whole model Bar model Base 10 Place value counters Column addition
Add with more than 4 digits	5	Part-whole model Bar model Place value counters Column addition
Add with up to 3 decimal places	5	Part-whole model Bar model Place value counters Column addition

Skill: Add 1-digit numbers within 10

Year: 1

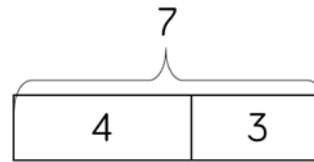
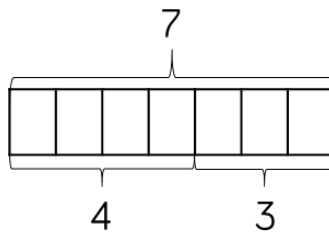
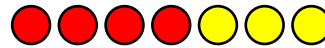
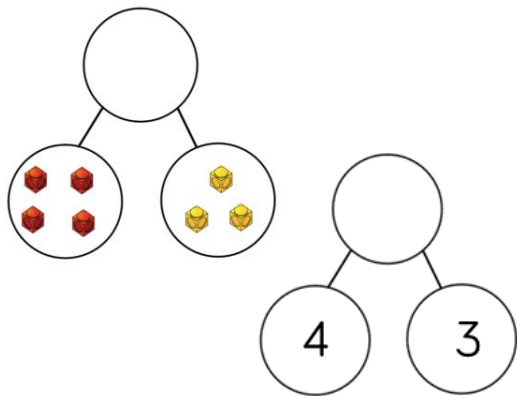

$$4 + 3 = 7$$

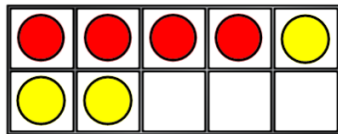
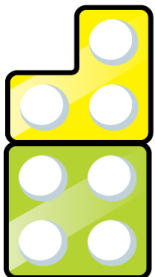
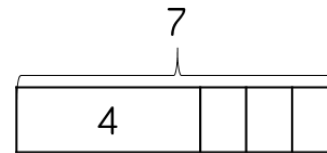

When adding numbers to 10, children can explore both aggregation and augmentation.

The part-whole model, discrete and continuous bar model, number shapes and ten frame support aggregation.

The combination bar model, ten frame, bead string and number track all support augmentation.

Skill: Add 1 and 2-digit numbers to 20

Year: 1/2

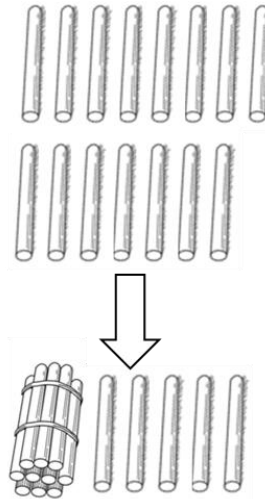
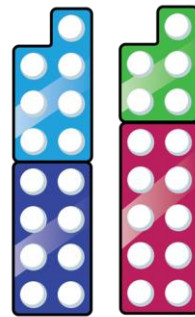
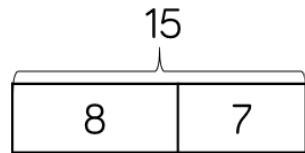
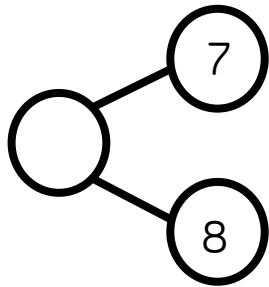

$$8 + 7 = 15$$

$$8 + 7 = 15$$

2 5

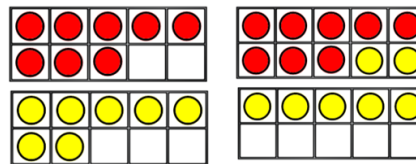
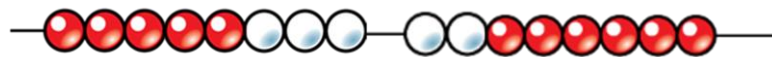
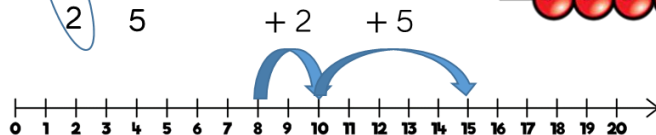

$$8 + 7 = 15$$

2 5

When adding one-digit numbers that cross 10, it is important to highlight the importance of ten ones equalling one ten. In Year 1, this is only done just by counting on. From Year 2, use different manipulatives can be used to represent this exchange alongside number lines to support children in understanding how to partition their jumps.

Skill: Add three 1-digit numbers

Year: 2

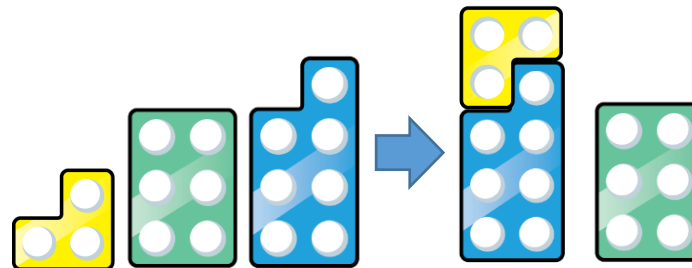
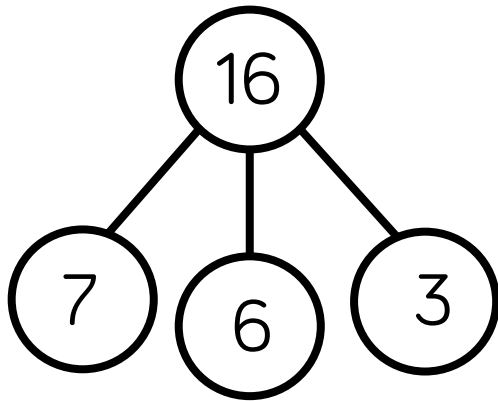

$$7 + 6 + 3 = 16$$

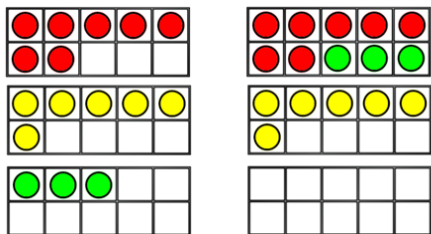

$$7 + 6 + 3 = 16$$

10

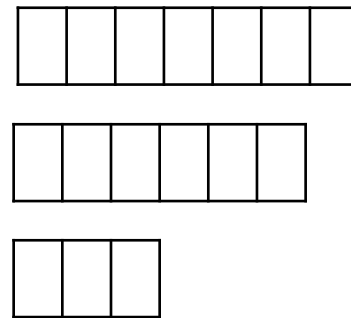

16

When adding three 1-digit numbers, children should be encouraged to look for number bonds to 10 or doubles to add the numbers more efficiently.

This supports children in their understanding of commutativity.

Manipulatives that highlight number bonds to 10 are effective when adding three 1-digit numbers.

Skill: Add 1-digit and 2-digit numbers to 100

Year: 2/3

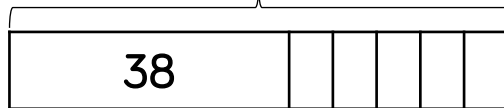
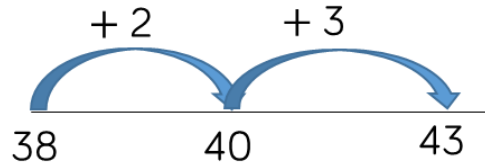
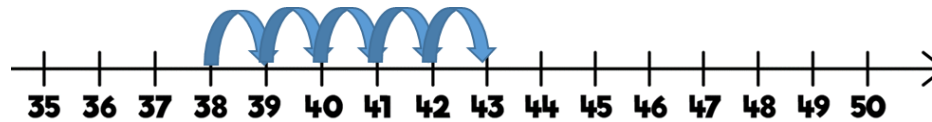
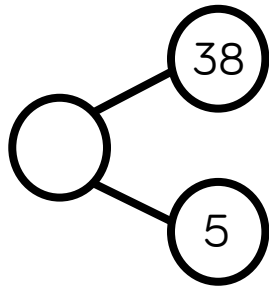

$$38 + 5 = 43$$

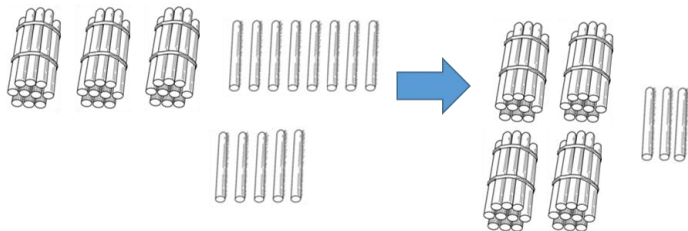

1	2	3	4	5	6	7	8	9	10
11	12	13	14	15	16	17	18	19	20
21	22	23	24	25	26	27	28	29	30
31	32	33	34	35	36	37	38	39	40
41	42	43	44	45	46	47	48	49	50
51	52	53	54	55	56	57	58	59	60
61	62	63	64	65	66	67	68	69	70
71	72	73	74	75	76	77	78	79	80
81	82	83	84	85	86	87	88	89	90
91	92	93	94	95	96	97	98	99	100

When adding single digits to a two-digit number, children should be encouraged to count on from the larger number.

They should also apply their knowledge of number bonds to add more efficiently e.g. $8 + 5 = 13$ so $38 + 5 = 43$.

Hundred squares and straws can support children to find the number bond to 10.

Skill: Add two 2-digit numbers to 100

Year: 2/3

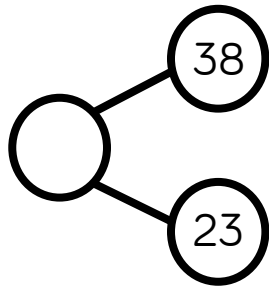

?

38	23
----	----

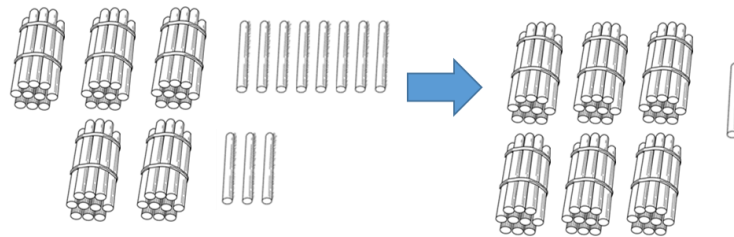
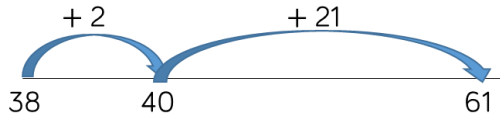

$$38 + 23 = 61$$

Tens	Ones

$$\begin{array}{r}
 38 \\
 + 23 \\
 \hline
 61 \\
 1
 \end{array}$$

Tens	Ones

Children can use a blank number line and other representations to count on to find the total. Encourage them to jump to multiples of 10 to become more efficient. From Year 3, encourage children to use the formal column method when calculating alongside straws, base 10 or place value counters. As numbers become larger, straws become less efficient.

Skill: Add numbers with up to 3 digits

Year: 3

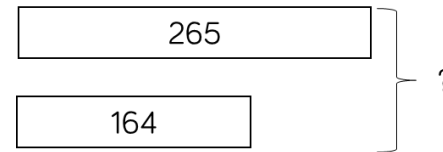
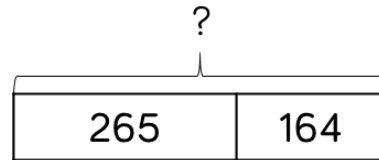
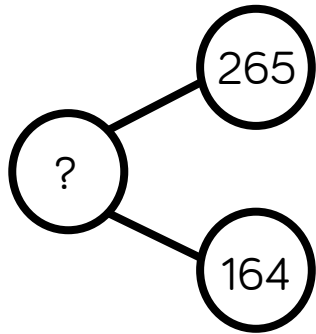

$$265 + 164 = 429$$

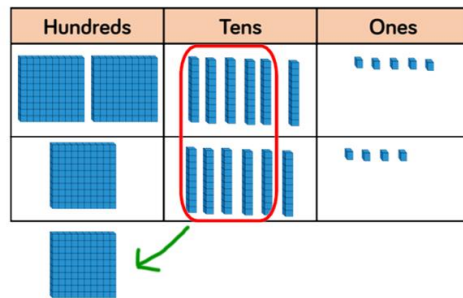

$$\begin{array}{r} 265 \\ + 164 \\ \hline 429 \\ \hline 1 \end{array}$$

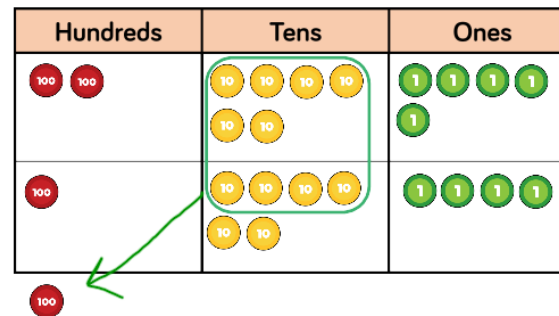

Base 10 and place value counters are the most effective manipulatives when adding numbers with up to 3 digits.

Ensure children write out their calculation alongside any concrete resources so they can see the links to the written column method.

Plain counters on a place value grid can also be used to support learning.

Skill: Add numbers with up to 4 digits

Year: 4

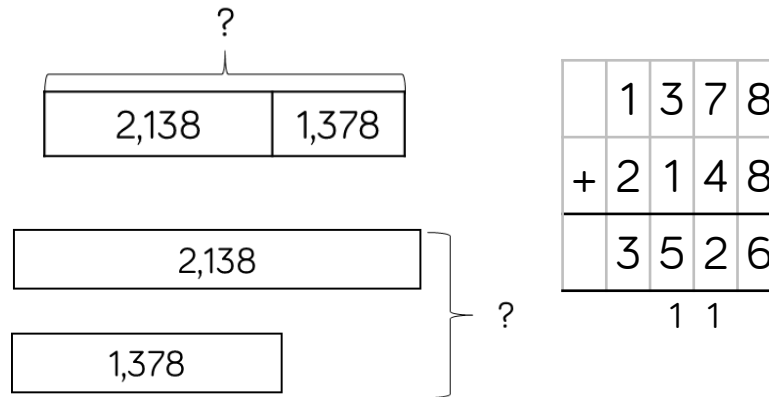
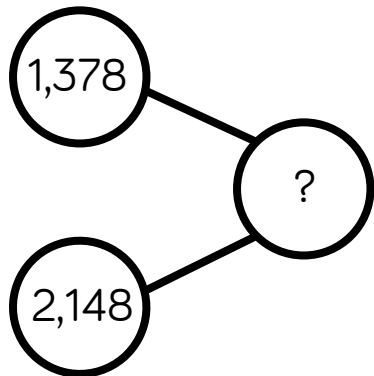

$$1,378 + 2,148 = 3,526$$

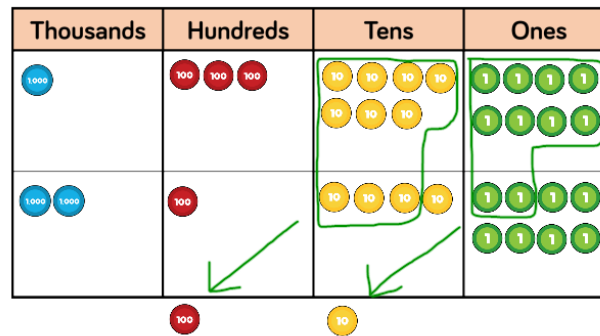
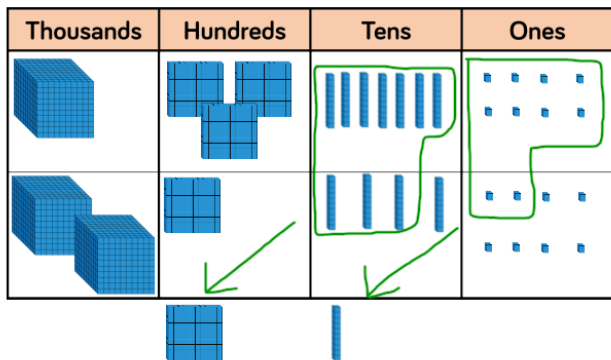

Base 10 and place value counters are the most effective manipulatives when adding numbers with up to 4 digits.

Ensure children write out their calculation alongside any concrete resources so they can see the links to the written column method.

Plain counters on a place value grid can also be used to support learning.

Skill: Add numbers with more than 4 digits

Year: 5/6

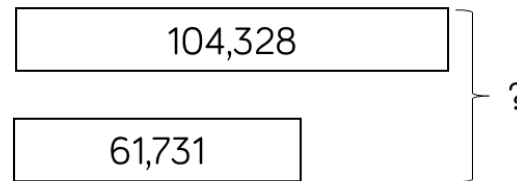
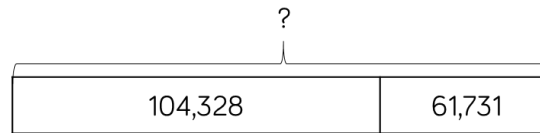
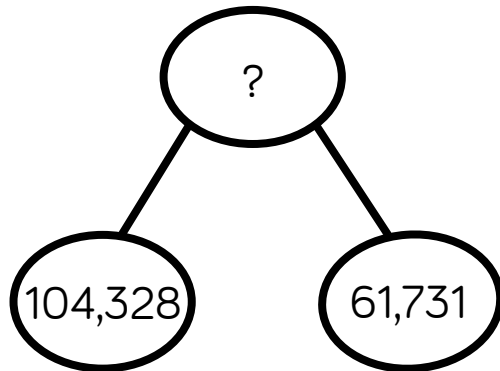

$$104,328 + 61,731 = 166,059$$

HTh	TTh	Th	H	T	O
100000		1000 1000 1000 1000	100 100 100	10 10	1 1 1 1 1 1 1 1
	10000 10000 10000 10000 10000 10000	1000	100 100 100 100 100 100 100	10 10 10	1

1	0	4	3	2	8
+	6	1	7	3	1
1	6	6	0	5	9

1

Place value counters or plain counters on a place value grid are the most effective concrete resources when adding numbers with more than 4 digits.

At this stage, children should be encouraged to work in the abstract, using the column method to add larger numbers efficiently.

Skill: Add with up to 3 decimal places

Year: 5

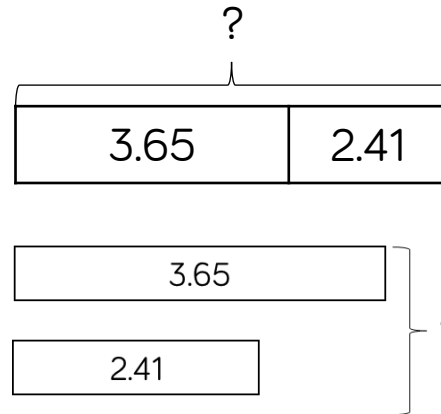
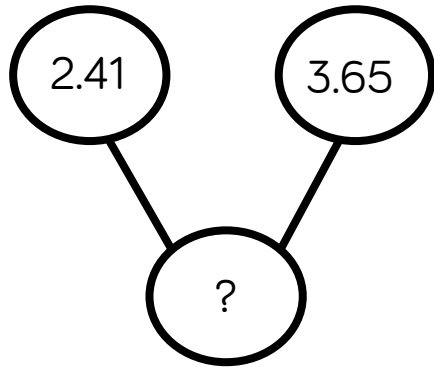

$$\begin{array}{r} 3.65 \\ + 2.41 \\ \hline 6.06 \\ 1 \end{array}$$

$$3.65 + 2.41 = 6.06$$

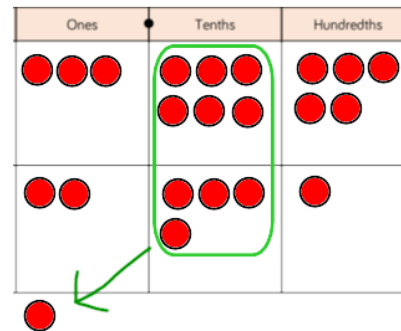
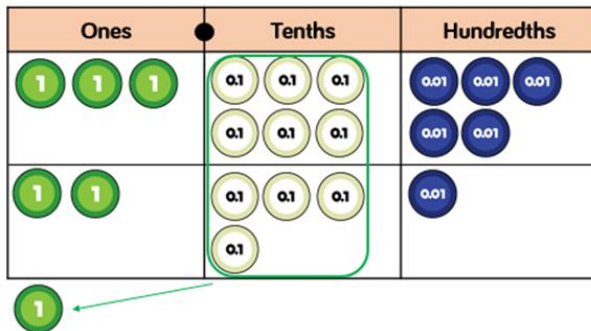

Place value counters and plain counters on a place value grid are the most effective manipulatives when adding decimals with 1, 2 and then 3 decimal places.

Ensure children have experience of adding decimals with a variety of decimal places. This includes putting this into context when adding money and other measures.

Subtraction

Skill	Year	Representations and models	
Subtract two 1-digit numbers to 10	1	Part-whole model Bar model Number shapes	Ten frames (within 10) Bead strings (10) Number tracks
Subtract 1 and 2-digit numbers to 20	1	Part-whole model Bar model Number shapes Ten frames (within 20)	Bead string (20) Number tracks Number lines (labelled) Straws
Subtract 1 and 2-digit numbers to 100	2	Part-whole model Bar model Number lines (labelled)	Number lines (blank) Straws Hundred square
Subtract two 2-digit numbers	2	Part-whole model Bar model Number lines (blank) Straws	Base 10 Place value counters

Skill	Year	Representations and models	
Subtract with up to 3-digits	3	Part-whole model Bar model	Base 10 Place value counters Column subtraction
Subtract with up to 4-digits	4	Part-whole model Bar model	Base 10 Place value counters Column subtraction
Subtract with more than 4 digits	5	Part-whole model Bar model	Place value counters Column subtraction
Subtract with up to 3 decimal places	5	Part-whole model Bar model	Place value counters Column subtraction

Skill: Subtract 1-digit numbers within 10

Year: 1

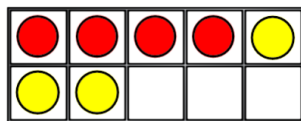
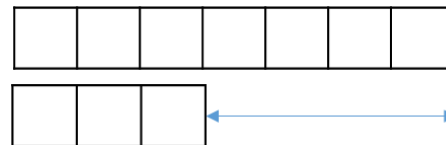
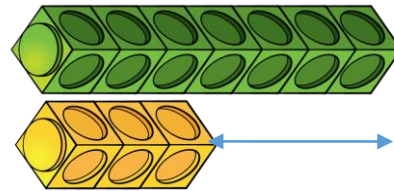
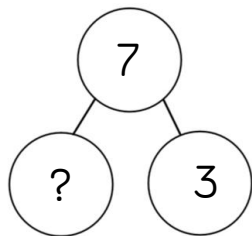

$$7 - 3 = 4$$

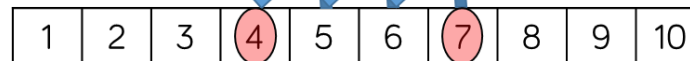
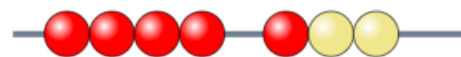
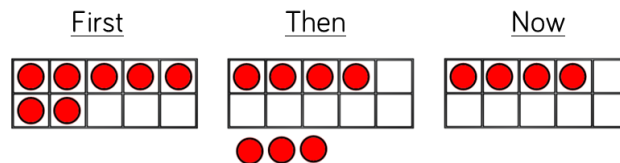
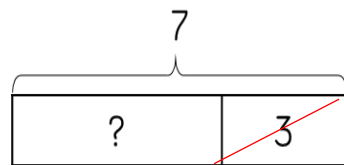
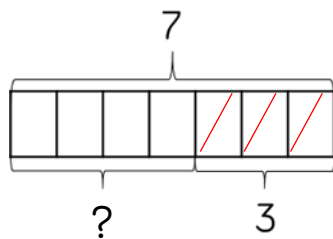

Part-whole models, bar models, ten frames and number shapes support partitioning.

Ten frames, number tracks, single bar models and bead strings support reduction.

Cubes and bar models with two bars can support finding the difference.

Skill: Subtract 1 and 2-digit numbers to 20

Year: 1/2

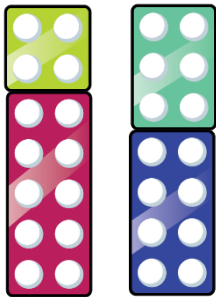
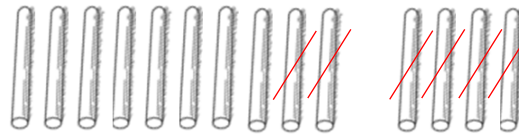
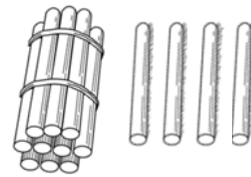
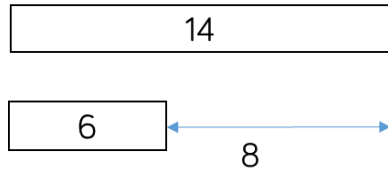
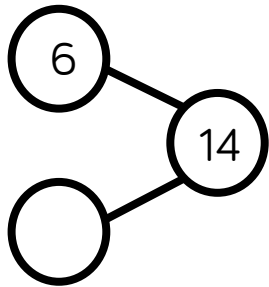

$$14 - 6 = 8$$

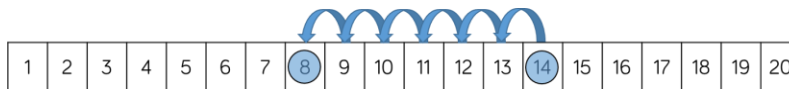

$$14 - 6 = 8$$

A number bond diagram for 14 - 6 = 8. The number 14 is circled. A line from 14 goes to 4, and another line goes to 2. The number 6 is written below the 4.

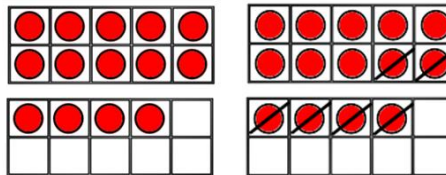
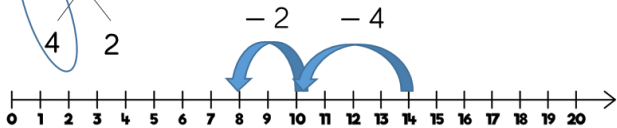

$$14 - 6 = 8$$

A number bond diagram for 14 - 6 = 8. The number 14 is circled. A line from 14 goes to 4, and another line goes to 2. The number 6 is written below the 4.

In Year 1, subtracting one-digit numbers that cross 10, is done by counting back, using objects, number tracks and number lines. From Year 2, children should be encouraged to find the number bond to 10 when partitioning the subtracted number. Ten frames, number shapes and number lines are particularly useful for this.

Skill: Subtract 1 and 2-digit numbers to 100

Year: 2/3

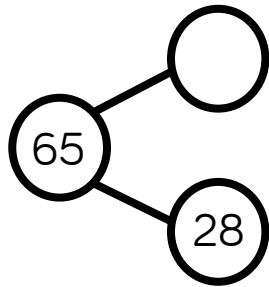

65

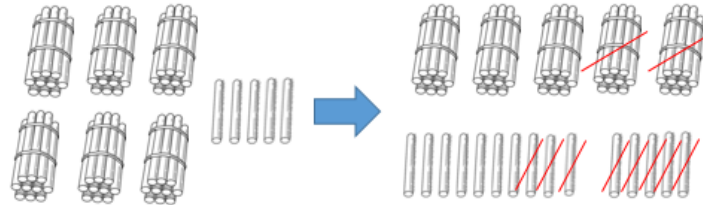
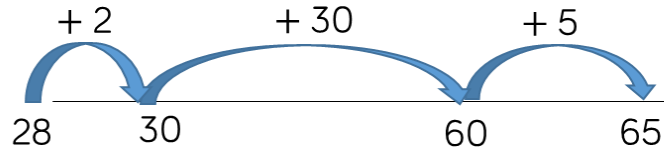
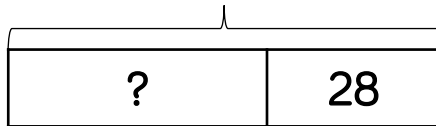

$$65 - 28 = 37$$

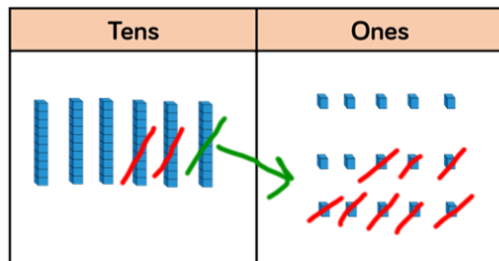

$$\begin{array}{r} 5 \ 1 \\ 65 \\ - 28 \\ \hline 37 \end{array}$$

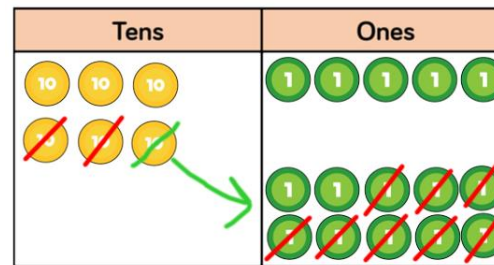

Children can also use a blank number line to count back to find the difference.

Encourage them to jump to multiples of 10 to become more efficient.

From Year 3, encourage children to use the formal column method when calculating alongside straws, base 10 or place value counters. As numbers become larger, straws become less efficient.

Skill: Subtract numbers with up to 3 digits

Year: 3

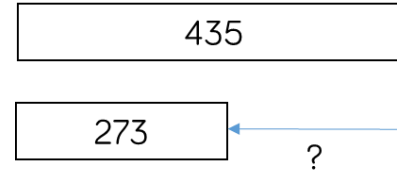
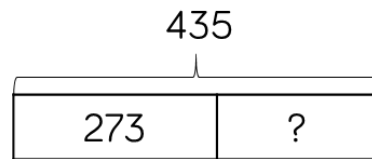
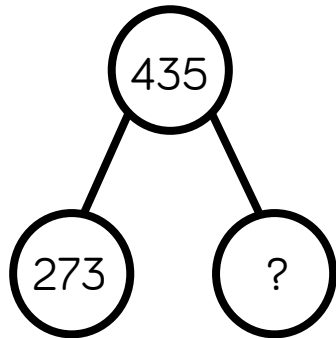

$$435 - 273 = 162$$

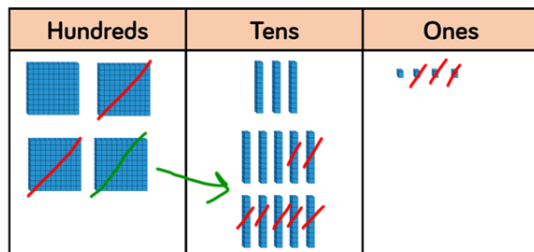

$$\begin{array}{r} \overset{3}{4} \overset{1}{3} 5 \\ - 273 \\ \hline 162 \end{array}$$

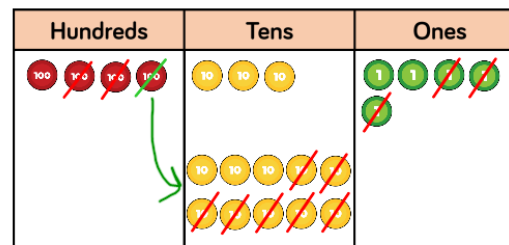

Base 10 and place value counters are the most effective manipulative when subtracting numbers with up to 3 digits.

Ensure children write out their calculation alongside any concrete resources so they can see the links to the written column method.

Plain counters on a place value grid can also be used to support learning.

Skill: Subtract numbers with up to 4 digits

Year: 4

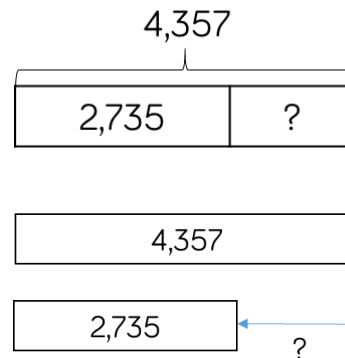
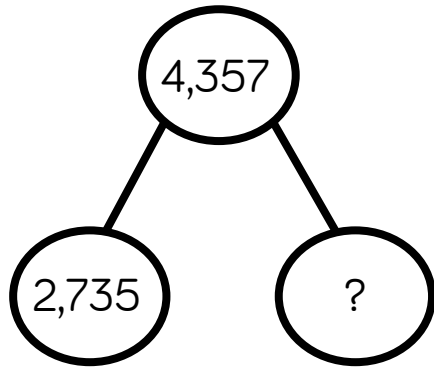

$$\begin{array}{r} \overset{3}{4} \overset{1}{3} 57 \\ - 2735 \\ \hline 1622 \end{array}$$

$$4,357 - 2,735 = 1,622$$

Thousands	Hundreds	Tens	Ones

Thousands	Hundreds	Tens	Ones

Base 10 and place value counters are the most effective manipulatives when subtracting numbers with up to 4 digits.

Ensure children write out their calculation alongside any concrete resources so they can see the links to the written column method.

Plain counters on a place value grid can also be used to support learning.

Skill: Subtract numbers with more than 4 digits

Year: 5/6

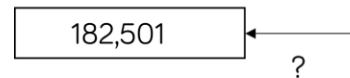
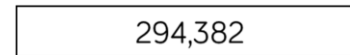
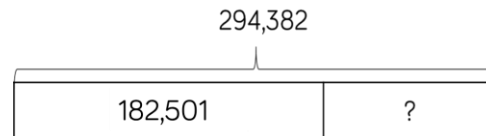
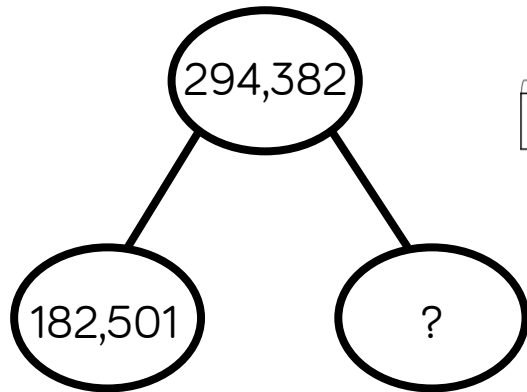

$$294,382 - 182,501 = 111,881$$

HTh	TTh	Th	H	T	O
100,000 (1), 100,000 (1) 	10,000 (3), 10,000 (3), 10,000 (3) 	1,000 (1), 1,000 (1), 1,000 (1) 	100 (3), 100 (3), 100 (3)	10 (3), 10 (3), 10 (3)	1 (1), 1 (1)
		1,000 (1) 	100 (3), 100 (3), 100 (3)	10 (3), 10 (3)	
			100 (3), 100 (3), 100 (3)		
			10 (3), 10 (3), 10 (3)		
			10 (3)		

	2	9	3	1 3	8	2
-	1	8	2	5	0	1
	1	1	1	8	8	1

Place value counters or plain counters on a place value grid are the most effective concrete resource when subtracting numbers with more than 4 digits.

At this stage, children should be encouraged to work in the abstract, using column method to subtract larger numbers efficiently.

Skill: Subtract with up to 3 decimal places

Year: 5/6

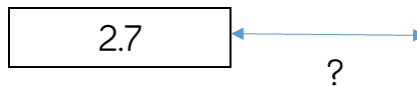
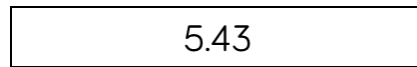
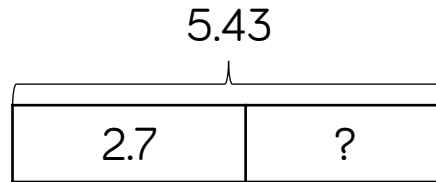
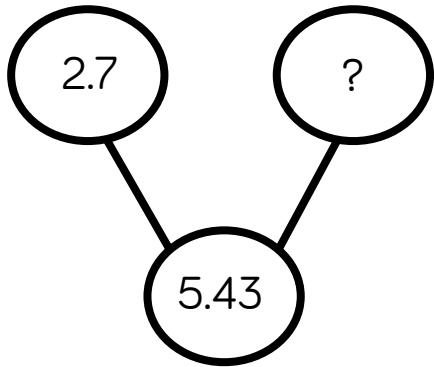

$$\begin{array}{r} 4 \quad 1 \\ \cancel{5}.43 \\ - 2.7 \\ \hline 2.73 \end{array}$$

$$5.43 - 2.7 = 2.73$$

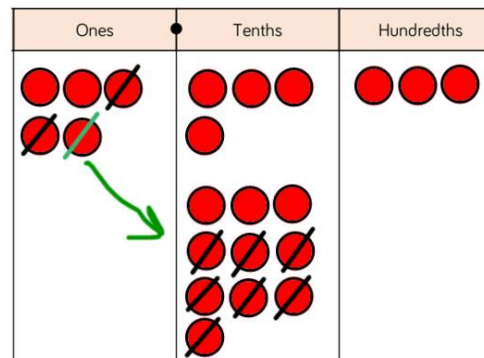
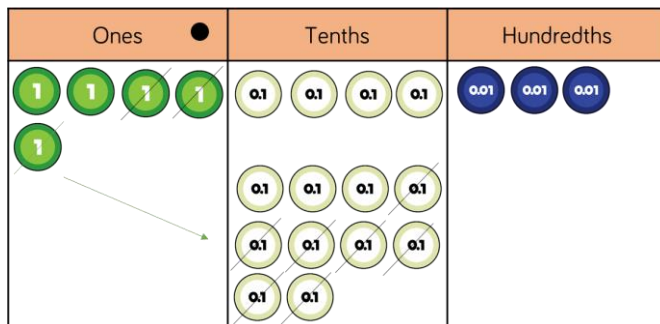

Place value counters and plain counters on a place value grid are the most effective manipulative when subtracting decimals with 1, 2 and then 3 decimal places.

Ensure children have experience of subtracting decimals with a variety of decimal places. This includes putting this into context when subtracting money and other measures.

Glossary

Addend - A number to be added to another.

Aggregation - combining two or more quantities or measures to find a total.

Augmentation - increasing a quantity or measure by another quantity.

Commutative - numbers can be added in any order.

Complement - in addition, a number and its complement make a total e.g. 300 is the complement to 700 to make 1,000

Difference - the numerical difference between two numbers is found by comparing the quantity in each group.

Exchange - Change a number or expression for another of an equal value.

Minuend - A quantity or number from which another is subtracted.

Partitioning - Splitting a number into its component parts.

Reduction - Subtraction as take away.

Subitise - Instantly recognise the number of objects in a small group without needing to count.

Subtrahend - A number to be subtracted from another.

Sum - The result of an addition.

Total - The aggregate or the sum found by addition.

Year 1 - 6

Calculation Policy

Multiplication and Division

[#MathsEveryoneCan](#)



Calculation Policy

Welcome to the White Rose Maths Calculation Policy.

This document is broken down into addition and subtraction, and multiplication and division.

At the start of each policy, there is an overview of the different models and images that can support the teaching of different concepts. These provide explanations of the benefits of using the models and show the links between different operations.

Each operation is then broken down into skills and each skill has a dedicated page showing the different models and images that could be used to effectively teach that concept.

Place Value Counters (Multiplication)

Hundreds	Tens	Ones
	3	4
	0	0
	0	0
	0	0
	0	0

$$\begin{array}{r} 34 \\ \times 5 \\ \hline 120 \\ 12 \end{array}$$

Hundreds	Tens	Ones
	4	4
	0	0
	0	0
	0	0
	0	0

$$\begin{array}{r} 44 \\ \times 32 \\ \hline 8 \\ 80 \\ 120 \\ + 1200 \\ \hline 1408 \\ 1 \end{array}$$

Benefits

Using place value counters is an effective way to support children's understanding of column multiplication. It is important that children write out their calculation alongside the equipment so they can see how the concrete and written match.

As numbers become larger in multiplication or the amounts of groups becomes higher, Base 10 / Dienes becomes less efficient due to the amount of equipment and number of exchanges needed. The counters should be used to support the understanding of the written method rather than support the arithmetic.

Place Value counters also support the area model of multiplication well. Children can see how to multiply 2-digit numbers by 2-digit numbers.

Skill: Multiply 2-digit numbers by 1-digit numbers

Year: 3/4

H	T	O
	3	4
x		5
	2	0
	1	5
	1	7
	0	0

34 × 5 = 170

H	T	O
	3	4
x		5
	1	7
	0	0

Teachers may decide to first look at the expanded column method before moving on to the short multiplication method.

The place value counters should be used to support the understanding of the method rather than supporting the multiplication as children should use times table knowledge.

There is an overview of skills linked to year groups to support consistency through out school. A glossary of terms is provided at the end of the calculation policy to support understanding of the key language used to teach the four operations.

Bar Model

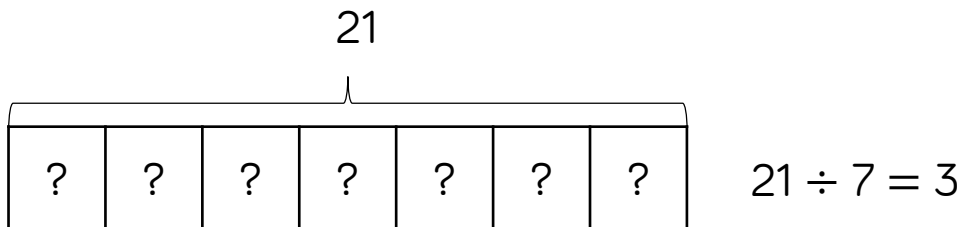
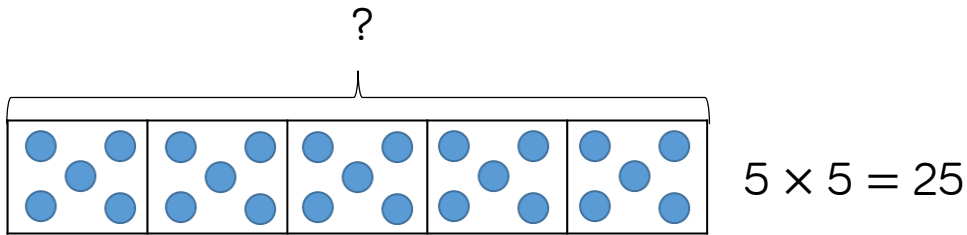

Benefits

Children can use the single bar model to represent multiplication as repeated addition. They could use counters, cubes or dots within the bar model to support calculation before moving on to placing digits into the bar model to represent the multiplication.

Division can be represented by showing the total of the bar model and then dividing the bar model into equal groups.

It is important when solving word problems that the bar model represents the problem.

Sometimes, children may look at scaling problems. In this case, more than one bar model is useful to represent this type of problem, e.g. There are 3 girls in a group. There are 5 times more boys than girls. How many boys are there?

The multiple bar model provides an opportunity to compare the groups.

Number Shapes



$$5 \times 4 = 20$$

$$4 \times 5 = 20$$

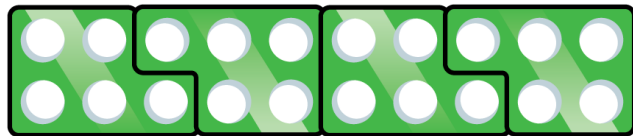

$$5 \times 4 = 20$$

$$4 \times 5 = 20$$

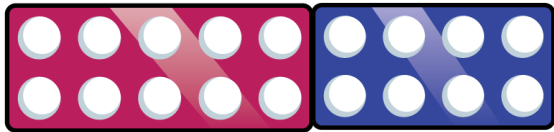

$$18 \div 3 = 6$$

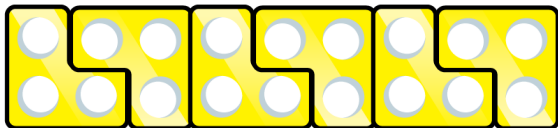

Benefits

Number shapes support children's understanding of multiplication as repeated addition.

Children can build multiplications in a row using the number shapes. When using odd numbers, encourage children to interlock the shapes so there are no gaps in the row. They can then use the tens number shapes along with other necessary shapes over the top of the row to check the total. Using the number shapes in multiplication can support children in discovering patterns of multiplication e.g. odd \times odd = even, odd \times even = odd, even \times even = even.

When dividing, number shapes support children's understanding of division as grouping. Children make the number they are dividing and then place the number shape they are dividing by over the top of the number to find how many groups of the number there are altogether e.g. There are 6 groups of 3 in 18.

Bead Strings



$$5 \times 3 = 15$$

$$3 \times 5 = 15$$

$$15 \div 3 = 5$$



$$5 \times 3 = 15$$

$$3 \times 5 = 15$$

$$15 \div 5 = 3$$



$$4 \times 5 = 20$$

$$5 \times 4 = 20$$

$$20 \div 4 = 5$$

Benefits

Bead strings to 100 can support children in their understanding of multiplication as repeated addition. Children can build the multiplication using the beads. The colour of beads supports children in seeing how many groups of 10 they have, to calculate the total more efficiently.

Encourage children to count in multiples as they build the number e.g. 4, 8, 12, 16, 20.

Children can also use the bead string to count forwards and backwards in multiples, moving the beads as they count.

When dividing, children build the number they are dividing and then group the beads into the number they are dividing by e.g. 20 divided by 4 - Make 20 and then group the beads into groups of four. Count how many groups you have made to find the answer.

Number Tracks

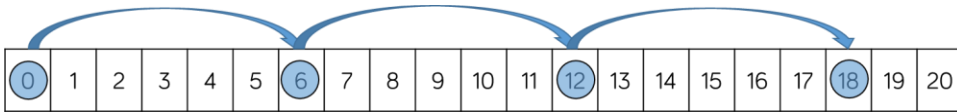
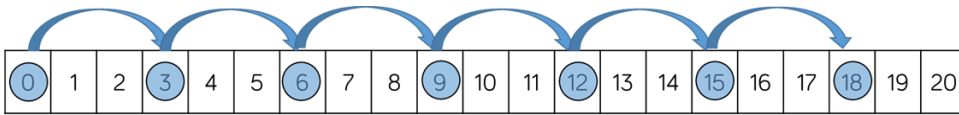

$$6 \times 3 = 18$$

$$3 \times 6 = 18$$

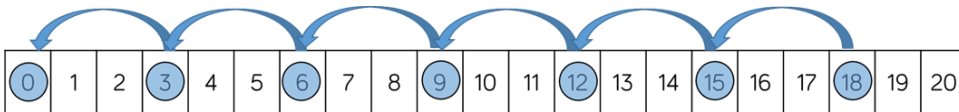

$$18 \div 3 = 6$$

Benefits

Number tracks are useful to support children to count in multiples, forwards and backwards. Moving counters or cubes along the number track can support children to keep track of their counting. Translucent counters help children to see the number they have landed on whilst counting.

When multiplying, children place their counter on 0 to start and then count on to find the product of the numbers.

When dividing, children place their counter on the number they are dividing and the count back in jumps of the number they are dividing by until they reach 0. Children record how many jumps they have made to find the answer to the division.

Number tracks can be useful with smaller multiples but when reaching larger numbers they can become less efficient.

Number Lines (labelled)

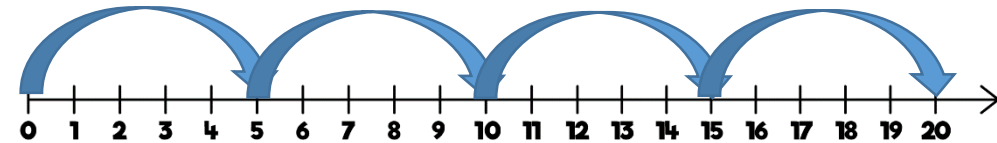
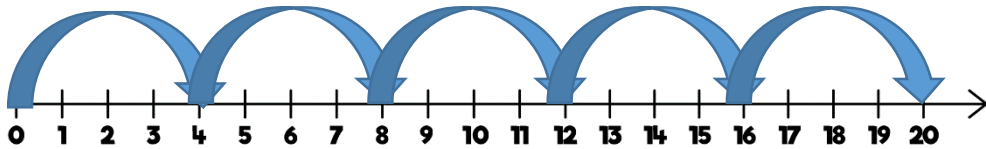

$$4 \times 5 = 20$$

$$5 \times 4 = 20$$

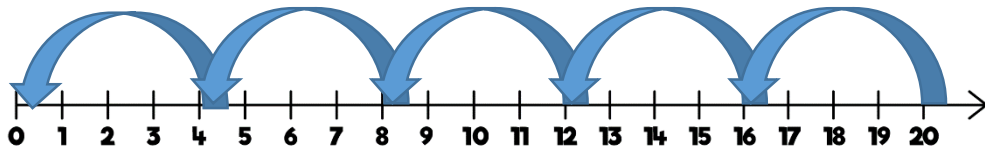

$$20 \div 4 = 5$$

Benefits

Labelled number lines are useful to support children to count in multiples, forwards and backwards as well as calculating single-digit multiplications.

When multiplying, children start at 0 and then count on to find the product of the numbers.

When dividing, start at the number they are dividing and the count back in jumps of the number they are dividing by until they reach 0.

Children record how many jumps they have made to find the answer to the division.

Labelled number lines can be useful with smaller multiples, however they become inefficient as numbers become larger due to the required size of the number line.

Number Lines (blank)

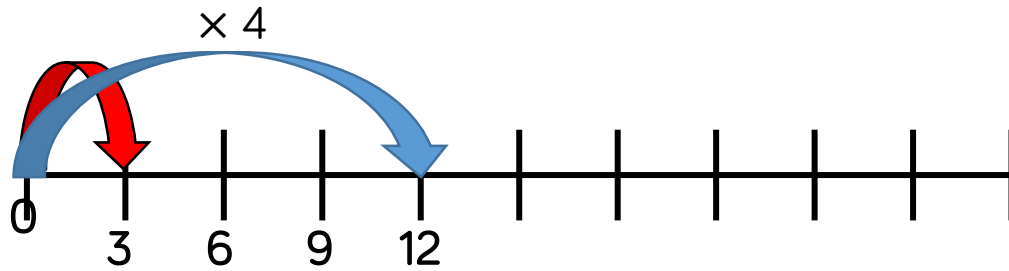

A red car travels 3 miles.

A blue car 4 times further.

How far does the blue car travel?

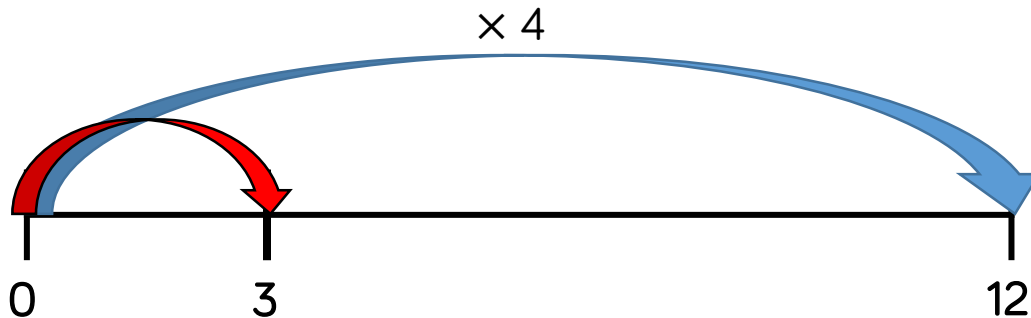

A blue car travels 12 miles.

A red car 4 times less.

How far does the red car travel?

Benefits

Children can use blank number lines to represent scaling as multiplication or division.

Blank number lines with intervals can support children to represent scaling accurately. Children can label intervals with multiples to calculate scaling problems.

Blank number lines without intervals can also be used for children to represent scaling.

Base 10/Dienes (multiplication)

Hundreds	Tens	Ones
		□□□□
		□□□□
		□□□□

$$\begin{array}{r}
 24 \\
 \times 3 \\
 \hline
 72 \\
 \hline
 1
 \end{array}$$

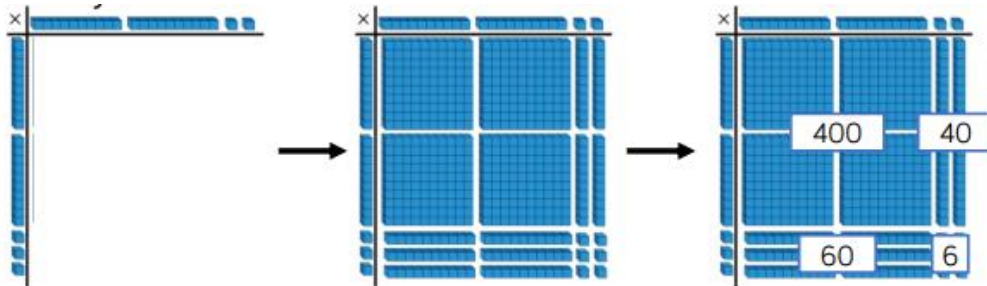

Benefits

Using Base 10 or Dienes is an effective way to support children's understanding of column multiplication. It is important that children write out their calculation alongside the equipment so they can see how the concrete and written representations match.

As numbers become larger in multiplication or the amounts of groups becomes higher, Base 10 / Dienes becomes less efficient due to the amount of equipment and number of exchanges needed.

Base 10 also supports the area model of multiplication well. Children use the equipment to build the number in a rectangular shape which they then find the area of by calculating the total value of the pieces. This area model can be linked to the grid method or the formal column method of multiplying 2-digits by 2-digits.

Base 10/Dienes (division)

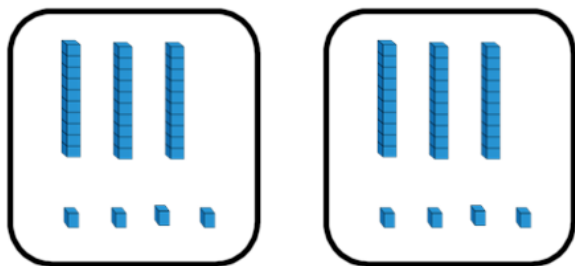

$$68 \div 2 = 34$$



Tens	Ones

$$72 \div 3 = 24$$

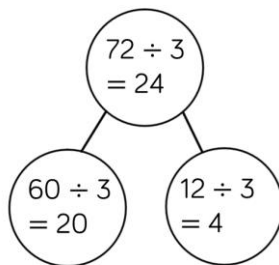

Benefits

Using Base 10 or Dienes is an effective way to support children's understanding of division.

When numbers become larger, it can be an effective way to move children from representing numbers as ones towards representing them as tens and ones in order to divide. Children can then share the Base 10/ Dienes between different groups e.g. by drawing circles or by rows on a place value grid.

When they are sharing, children start with the larger place value and work from left to right. If there are any left in a column, they exchange e.g. one ten for ten ones. When recording, encourage children to use the part-whole model so they can consider how the number has been partitioned in order to divide. This will support them with mental methods.

Place Value Counters (multiplication)



$$\begin{array}{r}
 34 \\
 \times 5 \\
 \hline
 170 \\
 \hline
 1 \ 2
 \end{array}$$

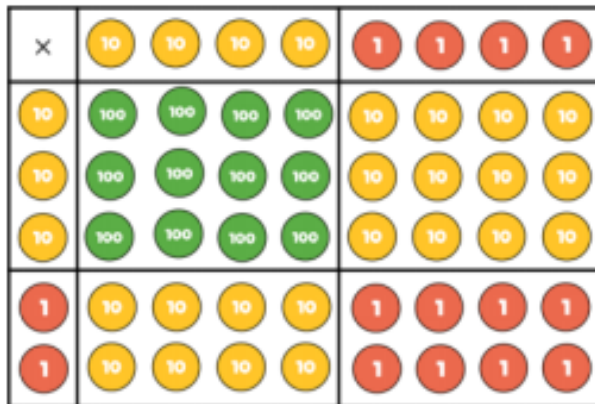

$$\begin{array}{r}
 44 \\
 \times 32 \\
 \hline
 88 \\
 880 \\
 + 1200 \\
 \hline
 1408 \\
 \hline
 1
 \end{array}$$

Benefits

Using place value counters is an effective way to support children's understanding of column multiplication. It is important that children write out their calculation alongside the equipment so they can see how the concrete and written match.

As numbers become larger in multiplication or the amounts of groups becomes higher, Base 10 / Dienes becomes less efficient due to the amount of equipment and number of exchanges needed. The counters should be used to support the understanding of the written method rather than support the arithmetic.

Place value counters also support the area model of multiplication well. Children can see how to multiply 2-digit numbers by 2-digit numbers.

Place Value Counters (division)

Tens	Ones
10 10	1 1 1 1
10 10	1 1 1 1
10 10	1 1 1 1
10 10	1 1 1 1

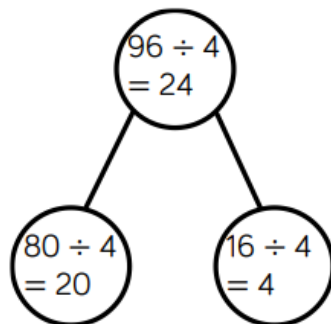

Thousands	Hundreds	Tens	Ones
1000 1000 1000 1000	100 100 100 100 100 100	10 10 10 10 10 10 10	1 1 1 1 1 1 1 1 1 1

$$\begin{array}{r}
 1223 \\
 4 \overline{) 4892}
 \end{array}$$

Benefits

Using place value counters is an effective way to support children's understanding of division.

When working with smaller numbers, children can use place value counters to share between groups. They start by sharing the larger place value column and work from left to right. If there are any counters left over once they have been shared, they exchange the counter e.g. exchange one ten for ten ones. This method can be linked to the part-whole model to support children to show their thinking.

Place value counters also support children's understanding of short division by grouping the counters rather than sharing them. Children work from left to right through the place value columns and group the counters in the number they are dividing by. If there are any counters left over after they have been grouped, they exchange the counter e.g. exchange one hundred for ten tens.

Times Tables

Skill	Year	Representations and models	
Recall and use multiplication and division facts for the 2-times table	2	Bar model Number shapes Counters Money	Ten frames Bead strings Number lines Everyday objects
Recall and use multiplication and division facts for the 5-times table	2	Bar model Number shapes Counters Money	Ten frames Bead strings Number lines Everyday objects
Recall and use multiplication and division facts for the 10-times table	2	Hundred square Number shapes Counters Money	Ten frames Bead strings Number lines Base 10

Skill	Year	Representations and models	
Recall and use multiplication and division facts for the 3-times table	3	Hundred square Number shapes Counters	Bead strings Number lines Everyday objects
Recall and use multiplication and division facts for the 4-times table	3	Hundred square Number shapes Counters	Bead strings Number lines Everyday objects
Recall and use multiplication and division facts for the 8-times table	3	Hundred square Number shapes	Bead strings Number tracks Everyday objects
Recall and use multiplication and division facts for the 6-times table	4	Hundred square Number shapes	Bead strings Number tracks Everyday objects

Skill	Year	Representations and models	
Recall and use multiplication and division facts for the 7-times table	4	Hundred square Number shapes	Bead strings Number lines
Recall and use multiplication and division facts for the 9-times table	4	Hundred square Number shapes	Bead strings Number lines
Recall and use multiplication and division facts for the 11-times table	4	Hundred square Base 10	Place value counters Number lines
Recall and use multiplication and division facts for the 12-times table	4	Hundred square Base 10	Place value counters Number lines

Skill: 2 times table

Year: 2

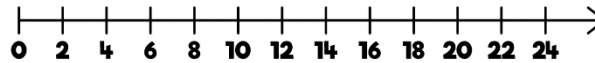
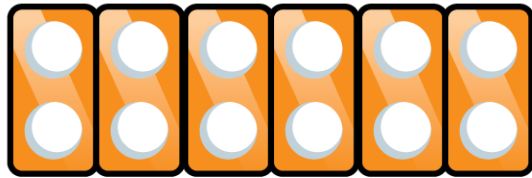

1	2	3	4	5	6	7	8	9	10
11	12	13	14	15	16	17	18	19	20
21	22	23	24	25	26	27	28	29	30
31	32	33	34	35	36	37	38	39	40
41	42	43	44	45	46	47	48	49	50

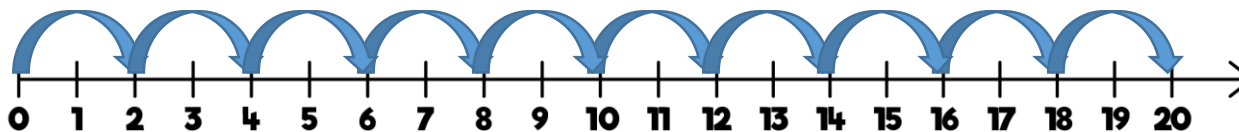
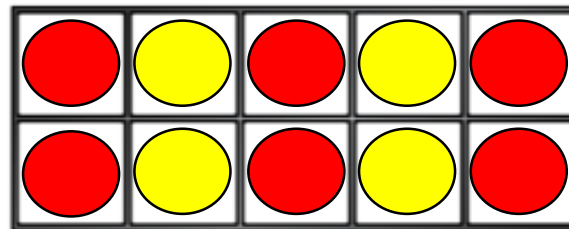

Encourage daily counting in multiples both forwards and backwards. This can be supported using a number line or a hundred square.

Look for patterns in the two times table, using concrete manipulatives to support. Notice how all the numbers are even and there is a pattern in the ones.

Use different models to develop fluency.

Skill: 5 times table

Year: 2

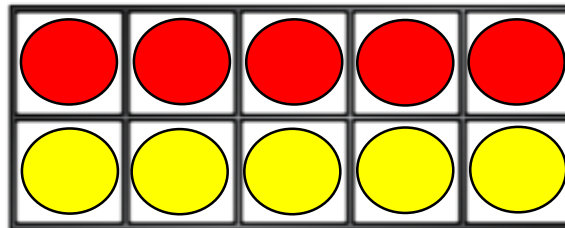
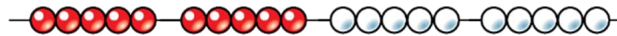
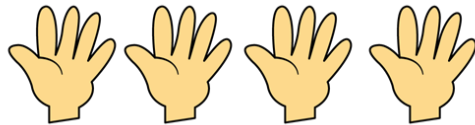
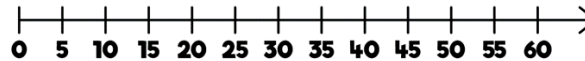
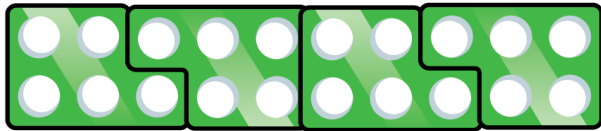

1	2	3	4	5	6	7	8	9	10
11	12	13	14	15	16	17	18	19	20
21	22	23	24	25	26	27	28	29	30
31	32	33	34	35	36	37	38	39	40
41	42	43	44	45	46	47	48	49	50

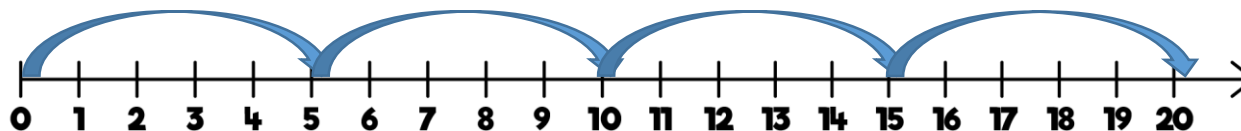
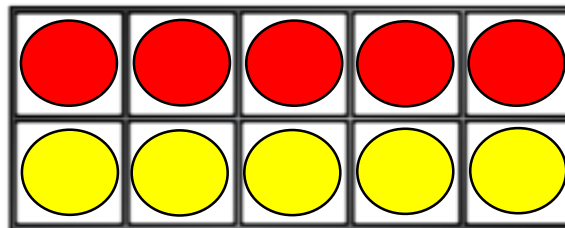

Encourage daily counting in multiples both forwards and backwards. This can be supported using a number line or a hundred square.

Look for patterns in the five times table, using concrete manipulatives to support. Notice the pattern in the ones as well as highlighting the odd, even, odd, even pattern.

Skill: 10 times table

Year: 2

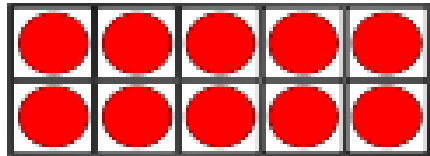
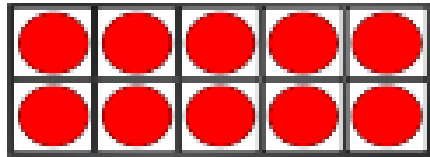
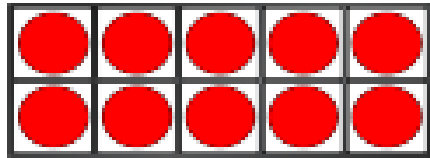
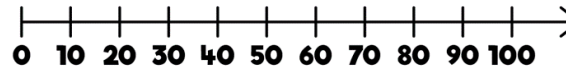
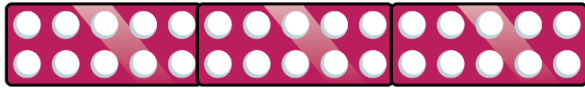

1	2	3	4	5	6	7	8	9	10
11	12	13	14	15	16	17	18	19	20
21	22	23	24	25	26	27	28	29	30
31	32	33	34	35	36	37	38	39	40
41	42	43	44	45	46	47	48	49	50
51	52	53	54	55	56	57	58	59	60
61	62	63	64	65	66	67	68	69	70
71	72	73	74	75	76	77	78	79	80
81	82	83	84	85	86	87	88	89	90
91	92	93	94	95	96	97	98	99	100



Encourage daily counting in multiples both forwards and backwards. This can be supported using a number line or a hundred square.

Look for patterns in the ten times table, using concrete manipulatives to support. Notice the pattern in the digits—the ones are always 0, and the tens increase by 1 ten each time.

Skill: 3 times table

Year: 3

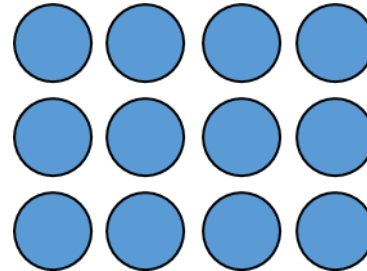
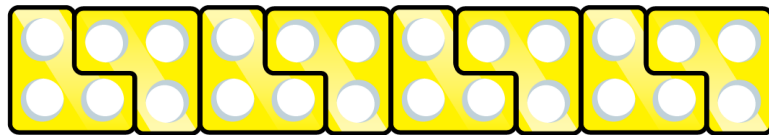

1	2	3	4	5	6	7	8	9	10
11	12	13	14	15	16	17	18	19	20
21	22	23	24	25	26	27	28	29	30
31	32	33	34	35	36	37	38	39	40
41	42	43	44	45	46	47	48	49	50

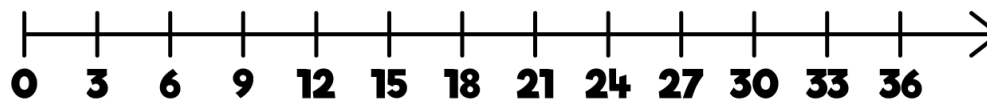
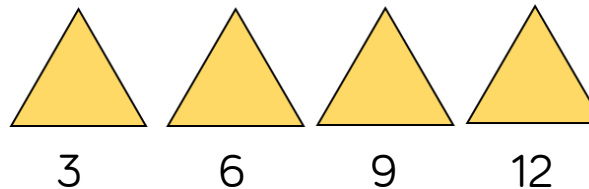

Encourage daily counting in multiples both forwards and backwards. This can be supported using a number line or a hundred square.

Look for patterns in the three times table, using concrete manipulatives to support. Notice the odd, even, odd, even pattern using number shapes to support. Highlight the pattern in the ones using a hundred square.

Skill: 4 times table

Year: 3

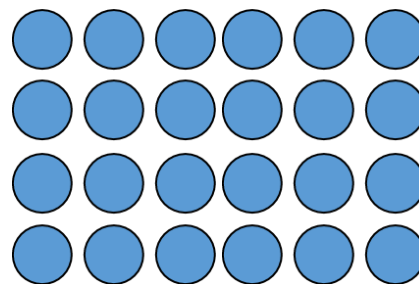

1	2	3	4	5	6	7	8	9	10
11	12	13	14	15	16	17	18	19	20
21	22	23	24	25	26	27	28	29	30
31	32	33	34	35	36	37	38	39	40
41	42	43	44	45	46	47	48	49	50

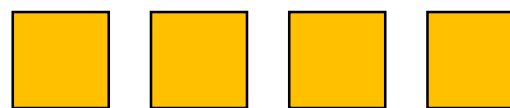

4 8 12 16

4	8	12	16	20
24	28	32	36	40
44	48	52	56	60

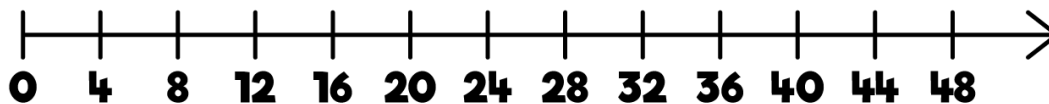

Encourage daily counting in multiples, supported by a number line or a hundred square. Look for patterns in the four times table, using manipulatives to support. Make links to the 2 times table, seeing how each multiple is double the twos. Notice the pattern in the ones within each group of five multiples. Highlight that all the multiples are even using number shapes to support.

Skill: 8 times table

Year: 3

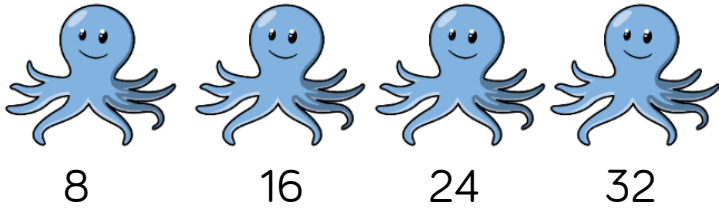
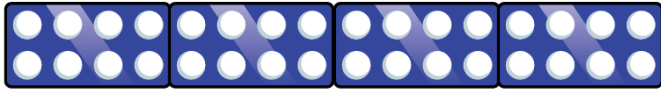

8	16	24	32	40
48	56	64	72	80

1	2	3	4	5	6	7	8	9	10
11	12	13	14	15	16	17	18	19	20
21	22	23	24	25	26	27	28	29	30
31	32	33	34	35	36	37	38	39	40
41	42	43	44	45	46	47	48	49	50
51	52	53	54	55	56	57	58	59	60
61	62	63	64	65	66	67	68	69	70
71	72	73	74	75	76	77	78	79	80
81	82	83	84	85	86	87	88	89	90
91	92	93	94	95	96	97	98	99	100

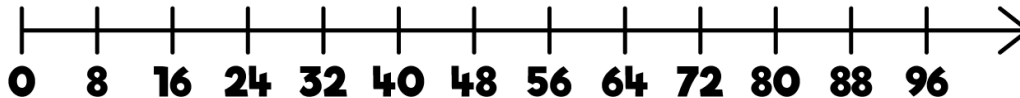

Encourage daily counting in multiples, supported by a number line or a hundred square. Look for patterns in the eight times table, using manipulatives to support. Make links to the 4 times table, seeing how each multiple is double the fours. Notice the pattern in the ones within each group of five multiples. Highlight that all the multiples are even using number shapes to support.

Skill: 6 times table

Year: 4



6	12	18	24	30
36	42	48	54	60
66	72	78	84	90

1	2	3	4	5	6	7	8	9	10
11	12	13	14	15	16	17	18	19	20
21	22	23	24	25	26	27	28	29	30
31	32	33	34	35	36	37	38	39	40
41	42	43	44	45	46	47	48	49	50
51	52	53	54	55	56	57	58	59	60
61	62	63	64	65	66	67	68	69	70
71	72	73	74	75	76	77	78	79	80
81	82	83	84	85	86	87	88	89	90
91	92	93	94	95	96	97	98	99	100

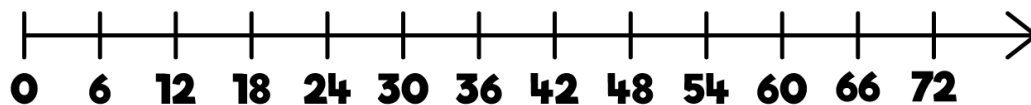

Encourage daily counting in multiples, supported by a number line or a hundred square. Look for patterns in the six times table, using manipulatives to support. Make links to the 3 times table, seeing how each multiple is double the threes. Notice the pattern in the ones within each group of five multiples. Highlight that all the multiples are even using number shapes to support.

Skill: 9 times table

Year: 4



9	18	27	36	45
54	63	72	81	90

1	2	3	4	5	6	7	8	9	10
11	12	13	14	15	16	17	18	19	20
21	22	23	24	25	26	27	28	29	30
31	32	33	34	35	36	37	38	39	40
41	42	43	44	45	46	47	48	49	50
51	52	53	54	55	56	57	58	59	60
61	62	63	64	65	66	67	68	69	70
71	72	73	74	75	76	77	78	79	80
81	82	83	84	85	86	87	88	89	90
91	92	93	94	95	96	97	98	99	100

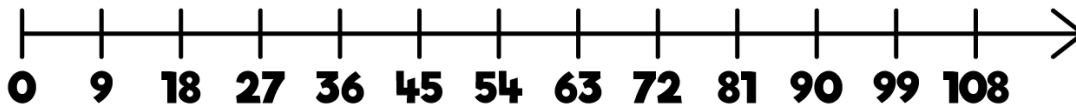

Encourage daily counting in multiples both forwards and backwards. This can be supported using a number line or a hundred square. Look for patterns in the nine times table, using concrete manipulatives to support. Notice the pattern in the tens and ones using the hundred square to support as well as noting the odd, even pattern within the multiples.

Skill: 7 times table

Year: 4



7	14	21	28	35
42	49	56	63	70

1	2	3	4	5	6	7	8	9	10
11	12	13	14	15	16	17	18	19	20
21	22	23	24	25	26	27	28	29	30
31	32	33	34	35	36	37	38	39	40
41	42	43	44	45	46	47	48	49	50
51	52	53	54	55	56	57	58	59	60
61	62	63	64	65	66	67	68	69	70
71	72	73	74	75	76	77	78	79	80
81	82	83	84	85	86	87	88	89	90
91	92	93	94	95	96	97	98	99	100

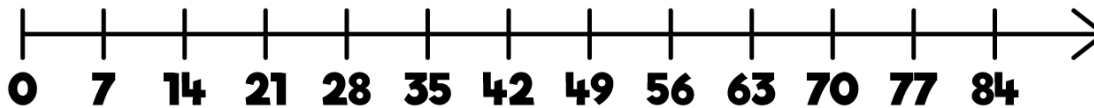

Encourage daily counting in multiples both forwards and backwards, supported by a number line or a hundred square. The seven times table can be trickier to learn due to the lack of obvious pattern in the numbers, however they already know several facts due to commutativity. Children can still see the odd, even pattern in the multiples using number shapes to support.

Skill: 11 times table

Year: 4

11	22	33	44	55	66
77	88	99	110	121	132

1	2	3	4	5	6	7	8	9	10
11	12	13	14	15	16	17	18	19	20
21	22	23	24	25	26	27	28	29	30
31	32	33	34	35	36	37	38	39	40
41	42	43	44	45	46	47	48	49	50
51	52	53	54	55	56	57	58	59	60
61	62	63	64	65	66	67	68	69	70
71	72	73	74	75	76	77	78	79	80
81	82	83	84	85	86	87	88	89	90
91	92	93	94	95	96	97	98	99	100

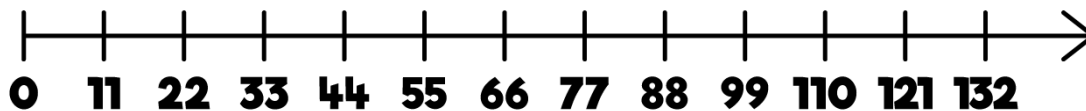
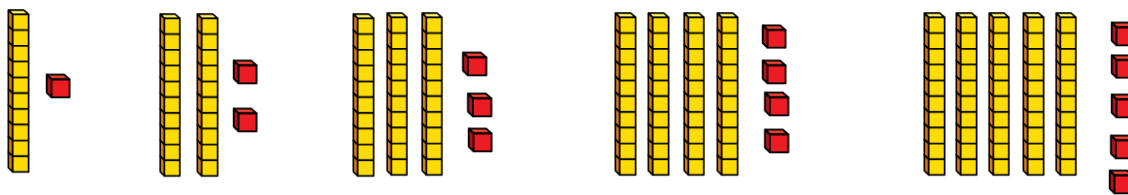
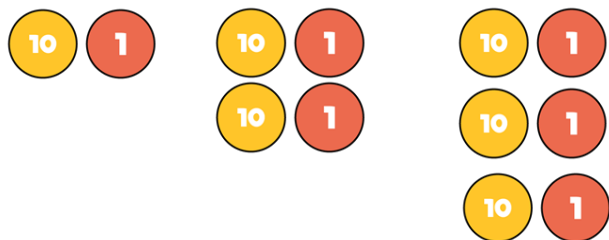

Encourage daily counting in multiples both forwards and backwards. This can be supported using a number line or a hundred square.

Look for patterns in the eleven times table, using concrete manipulatives to support. Notice the pattern in the tens and ones using the hundred square to support. Also consider the pattern after crossing 100

Skill: 12 times table

Year: 4

12	24	36	48	60
72	84	96	108	120
132	144			

1	2	3	4	5	6	7	8	9	10
11	12	13	14	15	16	17	18	19	20
21	22	23	24	25	26	27	28	29	30
31	32	33	34	35	36	37	38	39	40
41	42	43	44	45	46	47	48	49	50
51	52	53	54	55	56	57	58	59	60
61	62	63	64	65	66	67	68	69	70
71	72	73	74	75	76	77	78	79	80
81	82	83	84	85	86	87	88	89	90
91	92	93	94	95	96	97	98	99	100

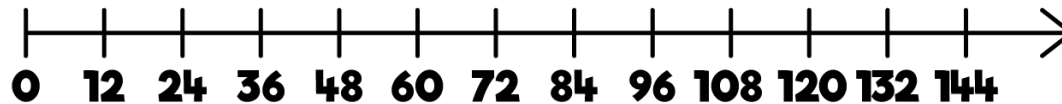
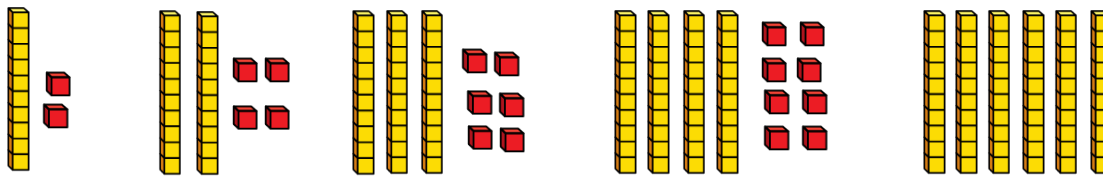
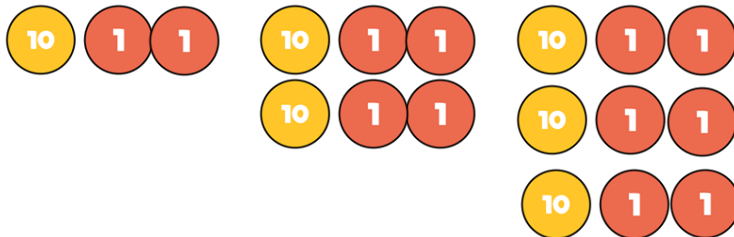

Encourage daily counting in multiples, supported by a number line or a hundred square. Look for patterns in the 12 times table, using manipulatives to support. Make links to the 6 times table, seeing how each multiple is double the sixes. Notice the pattern in the ones within each group of five multiples. The hundred square can support in highlighting this pattern.

Multiplication

Skill	Year	Representations and models	
Solve one-step problems with multiplication	1/2	Bar model Number shapes Counters	Ten frames Bead strings Number lines
Multiply 2-digit by 1-digit numbers	3/4	Place value counters Base 10	Expanded written method Short written method
Multiply 3-digit by 1-digit numbers	4	Place value counters Base 10	Short written method
Multiply 4-digit by 1-digit numbers	5	Place value counters	Short written method

Skill	Year	Representations and models	
Multiply 2-digit by 2-digit numbers	5	Place value counters Base 10	Short written method Grid method
Multiply 2-digit by 3-digit numbers	5	Place value counters	Short written method Grid method
Multiply 2-digit by 4-digit numbers	5/6	Formal written method	

Skill: Solve 1-step problems using multiplication

Year: 1/2

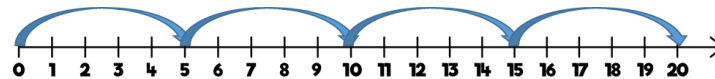
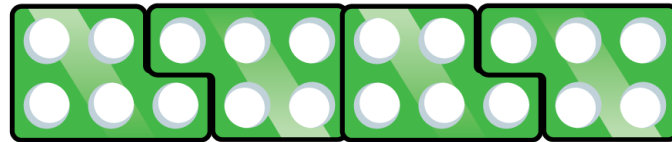
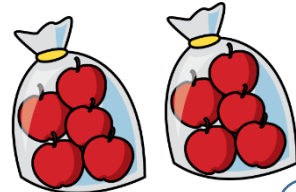
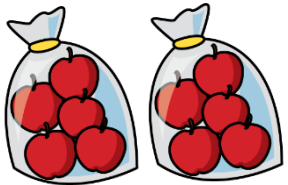

One bag holds 5 apples.
How many apples do 4 bags hold?

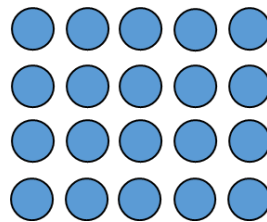
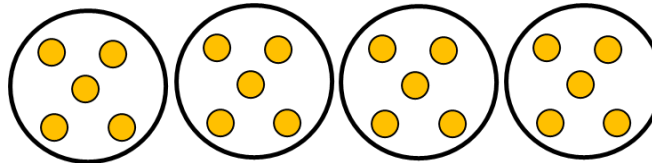
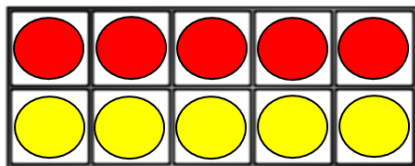
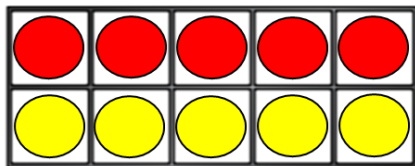

$$5 + 5 + 5 + 5 = 20$$

$$4 \times 5 = 20$$

$$5 \times 4 = 20$$

Children represent multiplication as repeated addition in many different ways.

In Year 1, children use concrete and pictorial representations to solve problems. They are not expected to record multiplication formally.

In Year 2, children are introduced to the multiplication symbol.

Skill: Multiply 2-digit numbers by 1-digit numbers

Year: 3/4

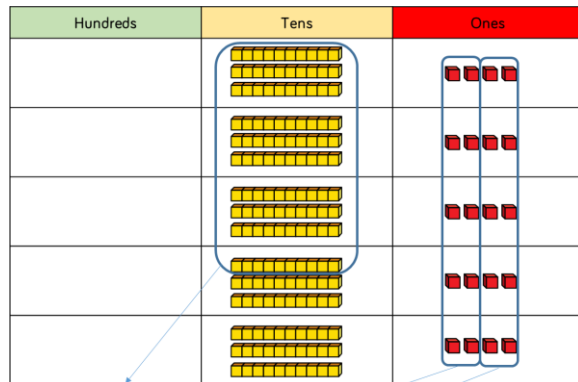

	H	T	O	
		3	4	
x			5	
		2	0	(5 × 4)
+	1	5	0	(5 × 30)
	1	7	0	

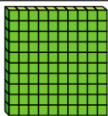

$$34 \times 5 = 170$$

	H	T	O	
		3	4	
x			5	
	1	7	0	
	1	2		

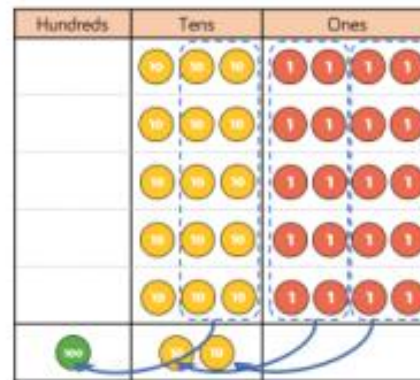

Informal methods and the expanded method are used in Year 3 before moving on to the short multiplication method in Year 4. Place value counters should be used to support the understanding of the method rather than supporting the multiplication, as children should use times table knowledge.

Skill: Multiply 3-digit numbers by 1-digit numbers

Year: 4

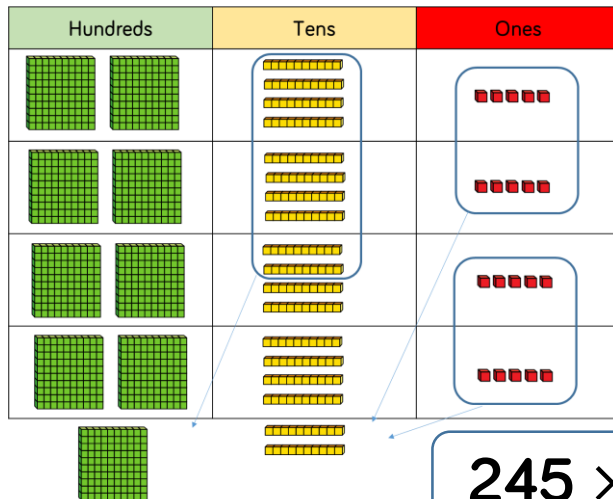

	H	T	O
	2	4	5
x			4
	9	8	0
	1	2	

$$245 \times 4 = 980$$

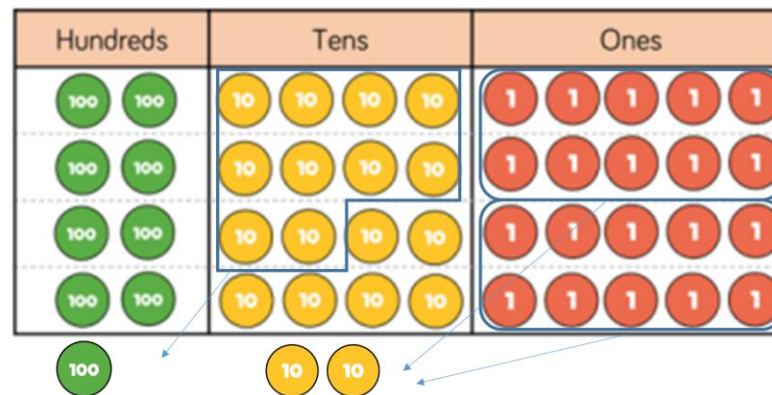

When moving to 3-digit by 1-digit multiplication, encourage children to move towards the short, formal written method.

Base 10 and place value counters continue to support the understanding of the written method. Limit the number of exchanges needed in the questions and move children away from resources when multiplying larger numbers.

Skill: Multiply 4-digit numbers by 1-digit numbers

Year: 5

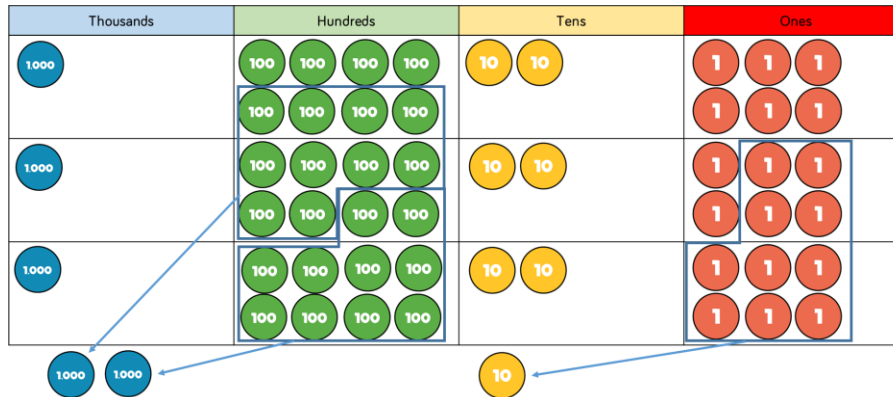

$$1,826 \times 3 = 5,478$$

	Th	H	T	O
	1	8	2	6
×				3
	5	4	7	8
	2		1	

When multiplying 4-digit numbers, place value counters are the best manipulative to use to support children in their understanding of the formal written method.

If children are multiplying larger numbers and struggling with their times tables, encourage the use of multiplication grids so children can focus on the use of the written method.

Skill: Multiply 2-digit numbers by 2-digit numbers

Year: 5

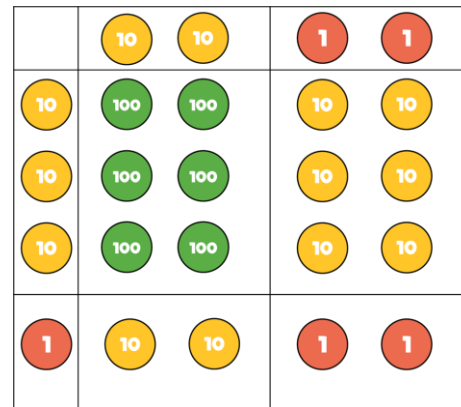
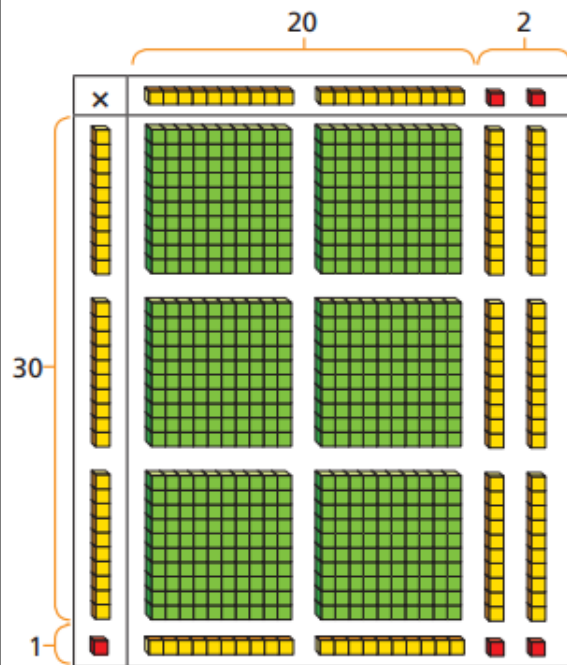

×	20	2
30	600	60
1	20	2

	H	T	O
		2	2
×		3	1
		2	2
	6	6	0
	6	8	2

$$22 \times 31 = 682$$

When multiplying a multi-digit number by 2-digits, use the area model to help children understand the size of the numbers they are using. This links to finding the area of a rectangle by finding the space covered by the Base 10. The grid method matches the area model as an initial written method before moving on to the formal written multiplication method.

Skill: Multiply 3-digit numbers by 2-digit numbers

Year: 5

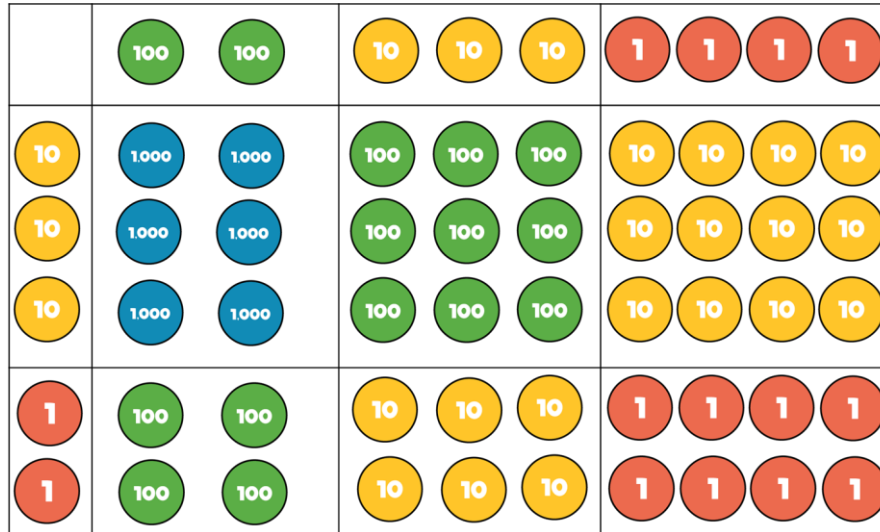

	Th	H	T	O
		2	3	4
×			3	2
		4	6	8
¹ 7	¹ 0	2	0	
7	4	8	8	

×	200	30	4
30	6,000	900	120
2	400	60	8

$$234 \times 32 = 7,488$$

Children can continue to use the area model when multiplying 3-digits by 2-digits. Place value counters become more efficient to use but Base 10 can be used to highlight the size of numbers.

Children should now move towards the formal written method, seeing the links with the grid method.

Skill: Multiply 4-digit numbers by 2-digit numbers

Year: 5/6

	TTh	Th	H	T	O
		2	7	3	9
×				2	8
2	1	9	1	2	
<small>2</small>	<small>5</small>	<small>3</small>	<small>7</small>		
5	4	7	8	0	
<small>1</small>		<small>1</small>			
7	6	6	9	2	

1

$$2,739 \times 28 = 76,692$$

When multiplying 4-digits by 2-digits, children should be confident in using the formal written method.

If they are still struggling with times tables, provide multiplication grids to support when they are focusing on the use of the method.

Consider where exchanged digits are placed and make sure this is consistent.

Division

Skill	Year	Representations and models	
Solve one-step problems with division (sharing)	1/2	Bar model Real life objects	Arrays Counters
Solve one-step problems with division (grouping)	1/2	Real life objects Number shapes Bead strings Ten frames	Number lines Arrays Counters
Divide 2-digits by 1-digit (no exchange sharing)	3	Straws Base 10 Bar model	Place value counters Part-whole model
Divide 2-digits by 1-digit (sharing with exchange)	3	Straws Base 10 Bar model	Place value counters Part-whole model

Skill	Year	Representations and models	
Divide 2-digits by 1-digit (sharing with remainders)	3/4	Straws Base 10 Bar model	Place value counters Part-whole model
Divide 2-digits by 1-digit (grouping)	4/5	Place value counters Counters	Place value grid Written short division
Divide 3-digits by 1-digit (sharing with exchange)	4	Base 10 Bar model	Place value counters Part-whole model
Divide 3-digits by 1-digit (grouping)	4/5	Place value counters Counters	Place value grid Written short division

Skill	Year	Representations and models	
Divide 4-digits by 1-digit (grouping)	5	Place value counters Counters	Place value grid Written short division
Divide multi-digits by 2-digits (short division)	6	Written short division	List of multiples
Divide multi-digits by 2-digits (long division)	6	Written long division	List of multiples

Skill: Solve 1-step problems using multiplication (sharing)

Year: 1/2

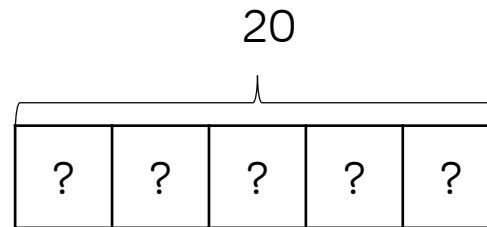
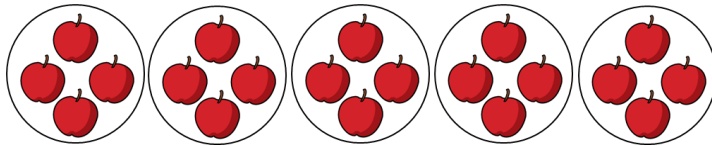

There are 20 apples altogether.
They are shared equally between 5 bags.
How many apples are in each bag?

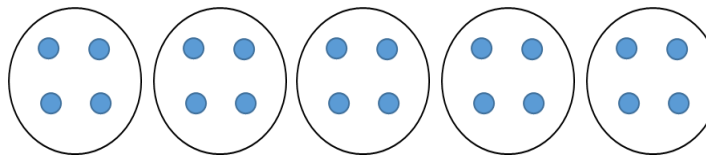
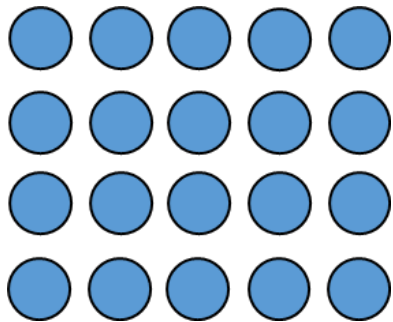

$$20 \div 5 = 4$$

Children solve problems by sharing amounts into equal groups.

In Year 1, children use concrete and pictorial representations to solve problems. They are not expected to record division formally.

In Year 2, children are introduced to the division symbol.

Skill: Solve 1-step problems using division (grouping)

Year: 1/2

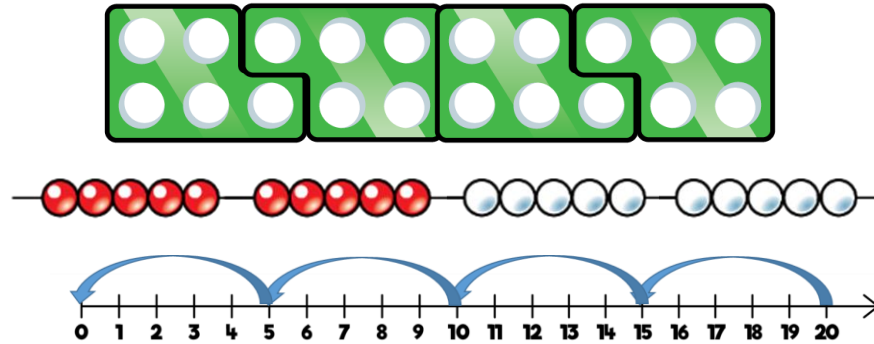
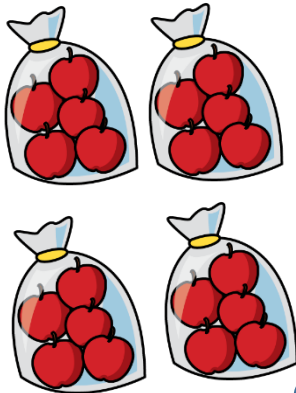

There are 20 apples altogether.
They are put in bags of 5.
How many bags are there?

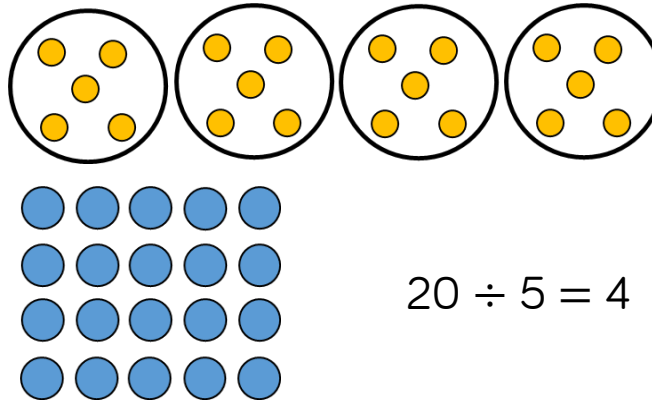
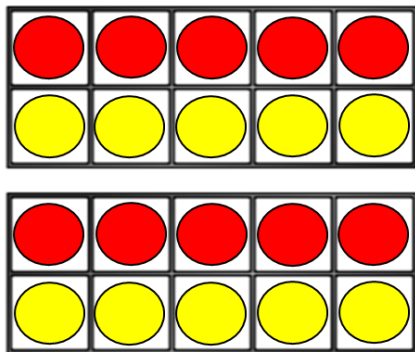

$$20 \div 5 = 4$$

Children solve problems by grouping and counting the number of groups. Grouping encourages children to count in multiples and links to repeated subtraction on a number line. They can use concrete representations in fixed groups such as number shapes which helps to show the link between multiplication and division.

Skill: Divide 2-digits by 1-digit (sharing with no exchange)

Year: 3

Tens	Ones
10 10	1 1 1 1
10 10	1 1 1 1

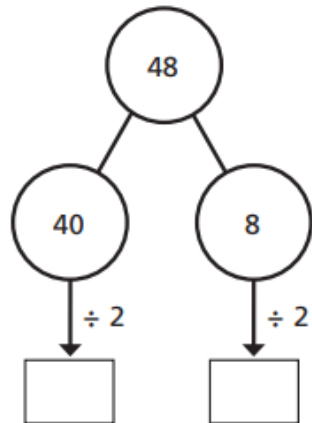
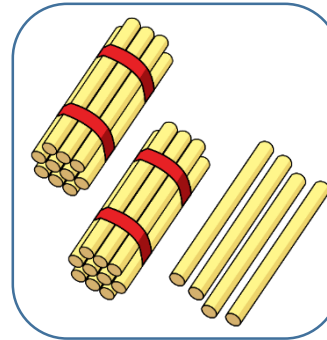
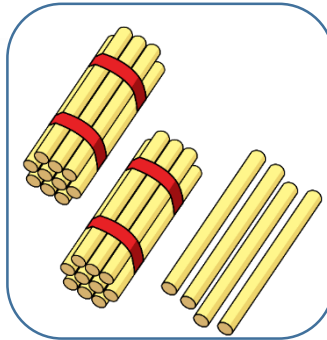

$$48 \div 2 = 24$$

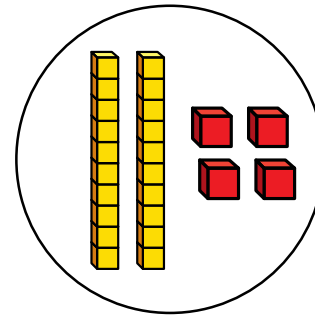
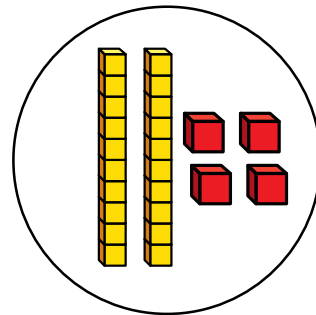

When dividing larger numbers, children can use manipulatives that allow them to partition into tens and ones.

Straws, Base 10 and place value counters can all be used to share numbers into equal groups.

Part-whole models can provide children with a clear written method that matches the concrete representation.

Skill: Divide 2-digits by 1-digit (sharing with exchange)

Year: 3/4

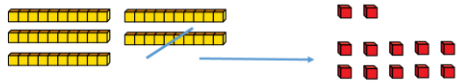

Tens	Ones

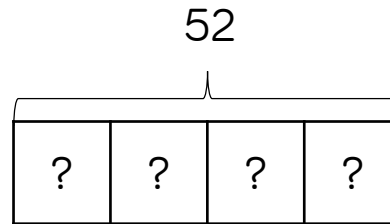

$$52 \div 4 = 13$$

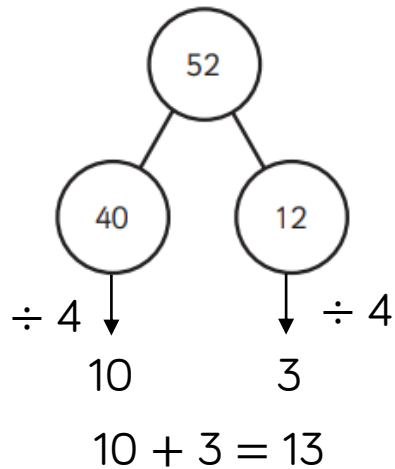

Diagram showing the base 10 blocks and place value grid for 52 divided by 4. The number 52 is represented by 5 tens rods and 2 one units. The place value grid shows the division process, with 10 ones in the ones column and 3 ones in the ones column, resulting in 13.

Tens	Ones

When dividing numbers involving an exchange, children can use Base 10 and place value counters to exchange one ten for ten ones.







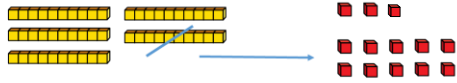

Children should start with the equipment outside the place value grid before sharing the tens and ones equally between the rows.

Flexible partitioning in a part-whole model supports this method.

Skill: Divide 2-digits by 1-digit (sharing with remainders)

Year: 3/4





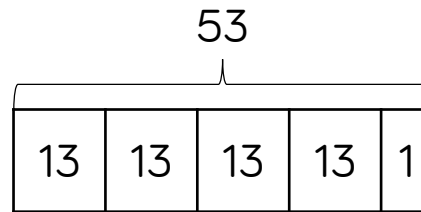



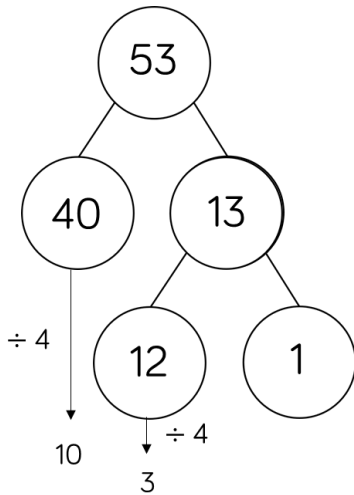

Tens	Ones
	
	
	
	



$$53 \div 4 = 13 \text{ r}1$$



Tens	Ones
	
	
	
	

When dividing numbers with remainders, children can use Base 10 and place value counters to exchange one ten for ten ones. Starting with the equipment outside the place value grid will highlight remainders, as they will be left outside the grid once the equal groups have been made. Flexible partitioning in a part-whole model supports this method.

Skill: Divide 2-digits by 1-digit (grouping)

Year: 5

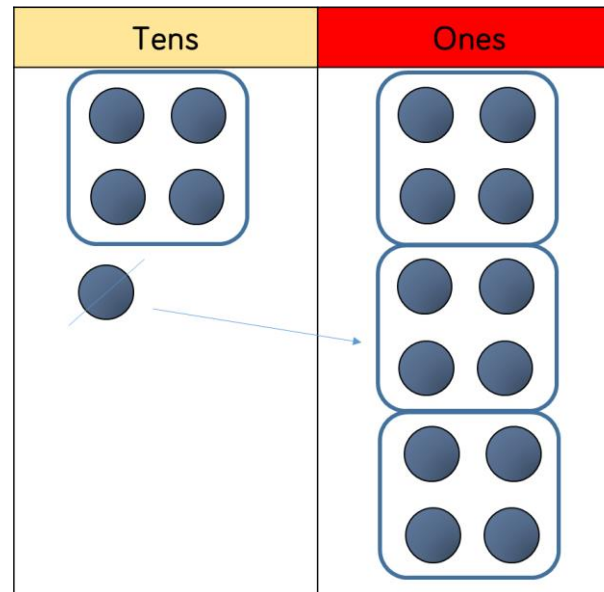
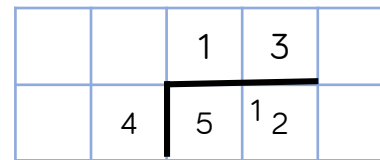
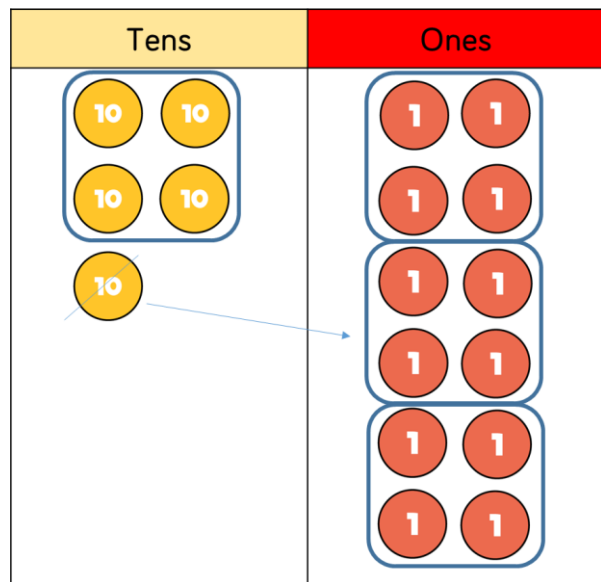

$$52 \div 4 = 13$$

When using the short division method, children use grouping. Starting with the largest place value, they group by the divisor.

Language is important here. Children should consider 'How many groups of 4 tens can we make?' and 'How many groups of 4 ones can we make?'

Remainders can also be seen as they are left ungrouped.

Skill: Divide 3-digits by 1-digit (sharing)

Year: 4

$$844 \div 4 = 211$$

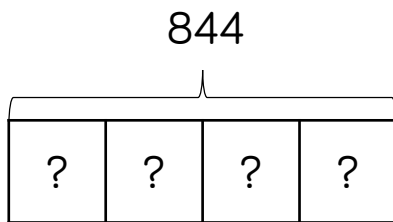

H	T	O
100 100	10	1
100 100	10	1
100 100	10	1
100 100	10	1

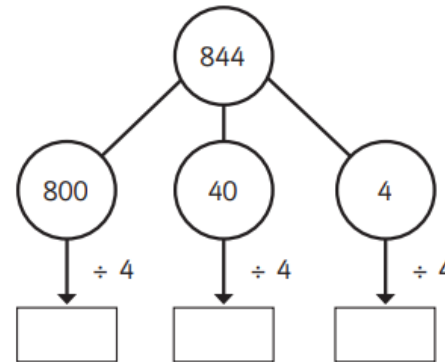

$$856 \div 4 = 214$$

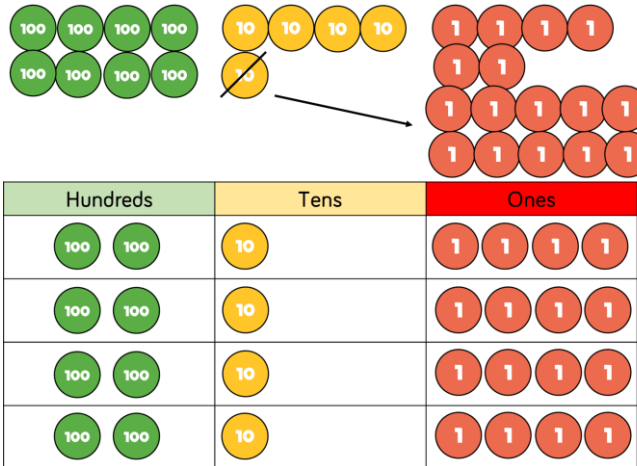
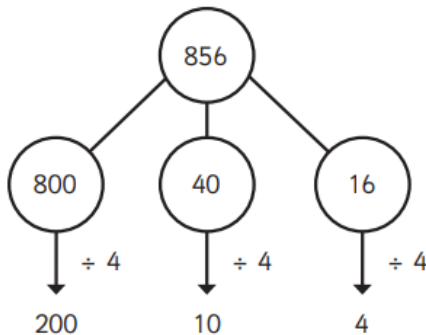

Children can continue to use place value counters to share 3-digit numbers into equal groups. Children should start with the equipment outside the place value grid before sharing the hundreds, tens and ones equally between the rows. This method can also help to highlight remainders. Flexible partitioning in a part-whole model supports this method.

Skill: Divide 3-digits by 1-digit (grouping)

Year: 5

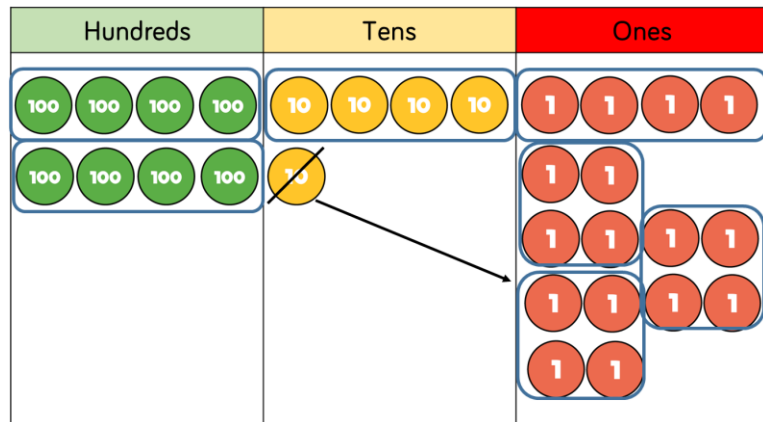

		2	1	4
	4	8	5	16

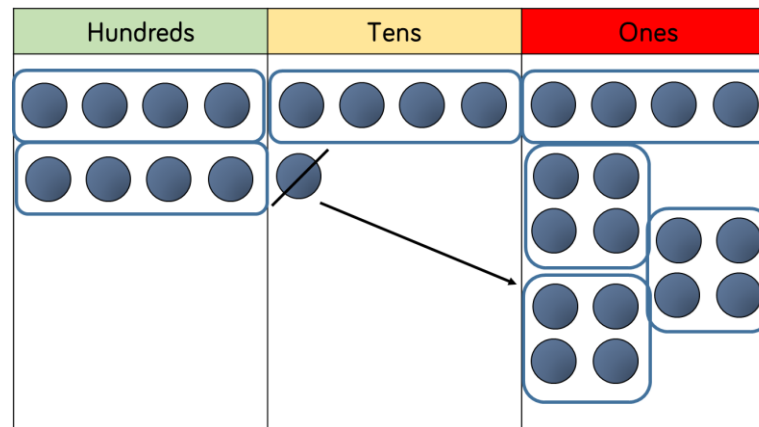

$$856 \div 4 = 214$$

Children can continue to use grouping to support their understanding of short division when dividing a 3-digit number by a 1-digit number.

Place value counters or plain counters can be used on a place value grid to support this understanding. Children can also draw their own counters and group them through a more pictorial method.

Skill: Divide 4-digits by 1-digit (grouping)

Year: 5

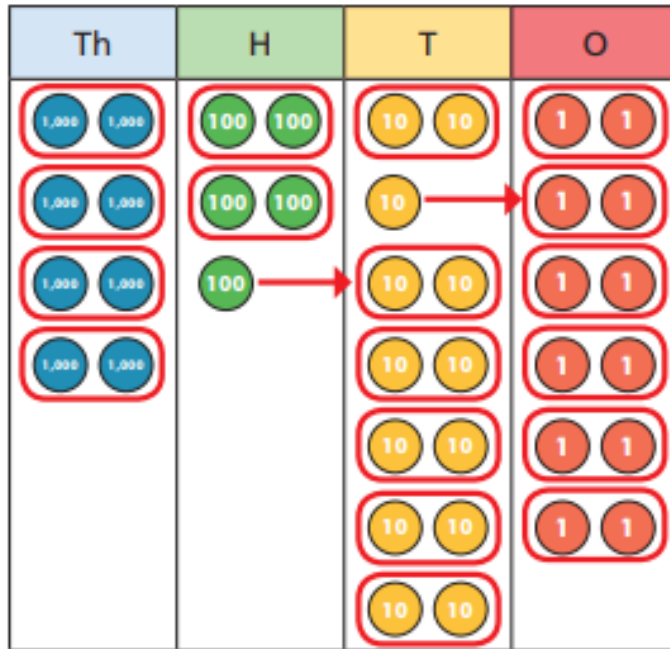

	4	2	6	6
2	8	5	¹ 3	¹ 2

$$8,532 \div 2 = 4,266$$

Place value counters or plain counters can be used on a place value grid to support children to divide 4-digits by 1-digit. Children can also draw their own counters and group them through a more pictorial method.

Children should be encouraged to move away from the concrete and pictorial when dividing numbers with multiple exchanges.

Skill: Divide multi digits by 2-digits (short division)

Year: 6

		0	3	6
	12	4	⁴ 3	⁷ 2

$$432 \div 12 = 36$$

$$7,335 \div 15 = 489$$

	0	4	8	9
15	7	⁷ 3	¹³ 3	¹³ 5

15	30	45	60	75	90	105	120	135	150
----	----	----	----	----	----	-----	-----	-----	-----

When children begin to divide up to 4-digits by 2-digits, written methods become the most accurate as concrete and pictorial representations become less effective. Children can write out multiples to support their calculations with larger remainders. Children will also solve problems with remainders where the quotient can be rounded as appropriate.

Skill: Divide multi-digits by 2-digits (long division)

Year: 6

		0	3	6
1	2	4	3	2
	-	3	6	0
			7	2
	-		7	2
				0

(x30)

$$12 \times 1 = 12$$

$$12 \times 2 = 24$$

$$12 \times 3 = 36$$

$$12 \times 4 = 48$$

$$12 \times 5 = 60$$

(x6)

$$12 \times 6 = 72$$

$$12 \times 7 = 84$$

$$12 \times 8 = 96$$

$$12 \times 7 = 108$$

$$12 \times 10 = 120$$

$$432 \div 12 = 36$$

$$7,335 \div 15 = 489$$

		0	4	8	9
15	7	3	3	5	
-	6	0	0	0	
	1	3	3	5	
-	1	2	0	0	
		1	3	5	
-		1	3	5	
				0	

(x400)

$$1 \times 15 = 15$$

$$2 \times 15 = 30$$

$$3 \times 15 = 45$$

$$4 \times 15 = 60$$

$$5 \times 15 = 75$$

(x80)

$$10 \times 15 = 150$$

(x9)

Children can also divide by 2-digit numbers using long division.

Children can write out multiples to support their calculations with larger remainders.

Children will also solve problems with remainders where the quotient can be rounded as appropriate.

Skill: Divide multi digits by 2-digits (long division)

Year: 6

$$372 \div 15 = 24 \text{ r}12$$

			2	4	r	1	2
1	5	3	7	2			
	-	3	0	0			
			7	2			
	-		6	0			
			1	2			

- $1 \times 15 = 15$
- $2 \times 15 = 30$
- $3 \times 15 = 45$
- $4 \times 15 = 60$
- $5 \times 15 = 75$
- $10 \times 15 = 150$

When a remainder is left at the end of a calculation, children can either leave it as a remainder or convert it to a fraction. This will depend on the context of the question.

Children can also answer questions where the quotient needs to be rounded according to the context.

			2	4	$\frac{4}{5}$
1	5	3	7	2	
	-	3	0	0	
			7	2	
	-		6	0	
			1	2	

$$372 \div 15 = 24 \frac{4}{5}$$

Glossary

Array – An ordered collection of counters, cubes or other item in rows and columns.

Commutative – Numbers can be multiplied in any order.

Dividend – In division, the number that is divided.

Divisor – In division, the number by which another is divided.

Exchange – Change a number or expression for another of an equal value.

Factor – A number that multiplies with another to make a product.

Multiplicand – In multiplication, a number to be multiplied by another.

Partitioning – Splitting a number into its component parts.

Product – The result of multiplying one number by another.

Quotient – The result of a division

Remainder – The amount left over after a division when the divisor is not a factor of the dividend.

Scaling – Enlarging or reducing a number by a given amount, called the scale factor